



LEGACYCARE FOR NEC

NEC PHONE SYSTEMS EXTENDED MAINTENANCE AND SUPPORT

BEST-IN-CLASS EXTENDED SUPPORT & MAINTENANCE FOR YOUR END-OF-LIFE NEC PHONE SYSTEM

We've built a holistic suite of services designed to support and extend the life of your NEC premise-based phone system. Whether your system is nearing end-of-life or already unsupported by NEC, LegacyCare ensures that your communication infrastructure remains reliable, efficient, and cost-effective.

Service Available for: NEC's SV9100, SV9300, SV9500, SL2100, SV8100, SV8300, SV8500, IPKII and IPK.



LegacyCare[™]

FOR NEC

We're NEC Certified Experts!



PHONE SYSTEM SERVICES INCLUDED

LEGACYCARE MAINTENANCE

Our on-site 14-point inspection and extended maintenance service can ensure continued system reliability and uptime.

LEGACYCARE SUPPORT

Our 24/7 US-based support team is here to get you operational and keep you there without any pressure to migrate off of your existing PBX.

LEGACYCARE PARTS

Legacy systems parts will eventually become scarce, so we work with our suppliers to source the parts you need to keep your system reliable.

LEGACYCARE GUIDANCE

When you're ready, our team of Solutions Consultants will discuss migration options to a new platform, best matched for your specific needs.

With LegacyCare for NEC you can count on:

- No Required Software Support (SWA Software Assurance is not required)
- 24/7 U.S. Based Support
- NEC-Certified Phone Technicians
- Legacy Parts Sourcing
- Remote & Onsite Support Options
- Available Nationwide
- Continued Support After NEC Exits Phone System Market
- No Pressure to Upgrade

Whether you're looking to maximize your existing investment today or prepare for a seamless transition to modern technology tomorrow, LegacyCare and our Guidance provides clear, unbiased insights and actionable strategies. Trust us to deliver the expertise and support you need to navigate these critical decisions with confidence.

LegacyCare for NEC is powered by Clarktel Telecommunications, Inc., a Double Diamond NEC Partner for the past 40 years; operating independent of NEC with our team of NEC-Certified Engineers who are available 24/7 to serve you long after NEC shuts its U.S. operations.

Learn more here: <https://www.clarktel.net/legacycare-nec-phone-maintenance-nationwide>



NEC

NDA-31963

Issue 3.02

UNIVERGE® SV9100

DT930/DT920 (ITK-8TCGX/ITK-8LCX) USER GUIDE

**NEC Enterprise Communication Technologies, Inc.
December 2023**

NEC Enterprise Communication Technologies, Inc. reserves the right to change the specifications, functions, or features at any time without notice.

NEC Enterprise Communication Technologies, Inc. has prepared this document for use by its employees and customers. The information contained herein is the property of NEC Enterprise Communication Technologies, Inc. and shall not be reproduced without prior written approval of NEC Enterprise Communication Technologies, Inc.

UNIVERGE is a registered trademark of NEC Corporation. Windows is a registered trademark of Microsoft Corporation. Bluetooth is a registered trademark of Bluetooth SIG, Inc. iPhone and iPad are registered trademarks of Apple, Inc.

Copyright 2023

**NEC Enterprise Communication Technologies, Inc.
3929 W. John Carpenter Freeway
Irving, TX 75063-9406**

TABLE OF CONTENTS

Section 1 Introduction

General	1
Face Layout	2
DT920 (ITK-8LCX-1)	2
DT930 (ITK-8TCGX-1)	2
Technical Specifications	3
Keys and Parts	5
DT920 (ITK-8LCX)	5
DT930 (ITK-8TCGX)	6
Telephone Basics	9
Telephone Startup	9
Favorite Screen	9
Information Area	10
Status Icon	10
Ext No./Ext Name	11
Call Screen	11
Local Softkey Indication.....	11
Call Screen	11
System Information Area	12
System Softkey Area	12
Local Softkey Area	12
Start the Call Screen	12
To Close Call Screen Automatically	13

TABLE OF CONTENTS

Line Screen	13
Count Lines on the Call Screen.....	13
Display Example for DT930 (ITK-8TCGX – Touch Panel Model)	14
Display Example for DT920 (ITK-8LCX – Self-Labeling Model).....	14
Phone Book	15
Call History	16
Menu and Setting	16
Installation	16
Attaching Handset	16
Connect the Line Cord.....	17
Attach the Directory Card	17
Attach or Remove Faceplate and DESI Printer Sheet.....	18
Removing Faceplate and DESI Printer Sheet.....	18
Attaching Faceplate and DESI Printer Sheet	18
Connect the Headset.....	18
Connect LAN Cable.....	19
Adjust Angle of Tilt Legs.....	20
Raising the Height of the Tilt Legs	20
Lowering the Tile Legs	20
Wall Mounting.....	20
Required Space	20
Wall Mount the Terminal	21
Mount Terminal on Wall Plate using Wall Mount Unit.....	22

TABLE OF CONTENTS

Section 2 Terminal Setup

Adjusting Volumes	23
Adjust Handset Receiver Volume.....	23
Adjust Speaker Volume	23
Adjust Ringer Tone.....	24
Setting Headset Ringing	24
Setting Ringer Tone	24
Distinctive Ringing Patterns to Distinguish Internal and External Incoming Calls – Provided	24
Distinctive Ringing Patterns to Distinguish Internal and External Incoming Calls – Not Provided.....	24
Setting Illumination Pattern for Call Indicator Lamp	26
Enabling/Disabling RTP Alarm	26
Enabling/Disabling DTMF Tone	26
Setting Key Touch Tone	27
Setting Music On Hold	27
Setting the Prefix	27
Setting Calendar Format	27
Setting Time Format	28
Enabling/Disabling Volume Level Display	28

TABLE OF CONTENTS

Setting Screen Saver	28
Setting Brightness of LCD Back Light	29
Enabling/Disabling LCD Back Light Fade Control	29
Changing Font Size	29
Setting a Language	29
Selecting Wallpaper	30
Setting Font Colors	30
Turning Display Off	31
Changing the Theme	31
Enabling/Disabling Animation	32
Screen When the Phone Starts	32
Setting Home Screen	32
Register a Home URL	32
To Start Up the Phone	33
Changing the Password	33
Setting Security	34
Setting Usability	34
Resetting Terminal Settings	34
Downloading a File	35

TABLE OF CONTENTS

Backing Up or Restoring the Terminal Setting Data	36
Back Up the Terminal Setting Data	36
Restore the Terminal Setting Data	38
Making/Answering Calls with a Headset	40
Make a Call Using a Headset	40
Answer a Call Using a Headset	40
Setting a Bluetooth Device	41
Enable the Bluetooth Function	41
Pair and Connect the Bluetooth	41
Check the Pairing Device And Disconnect	43
Change Inquiry Time	43
Display Bluetooth Module Information	43
Multi-Window Service	44
Switching XML Applications	44
Existing XML Applications	45
Launching the Fifth Application	45
Icon Display at XML Application Update	46

Section 3 Basic Operation

Shortcut	47
Favorite Screen	48
Shortcut Name	48
Register a Shortcut	49

TABLE OF CONTENTS

Use a Shortcut.....	50
Edit Shortcut	52
Delete a Shortcut.....	53
From a Registered Shortcut.....	53
From the User Setting.....	53
To Change Shortcut Display	55
System	55
Use the System Softkey.....	55
Phone Book	56
Personal Phone Book.....	56
Search for a Person	56
Make Calls using the Phone Book.....	57
From Candidate List.....	57
From Shortcut Detail	57
Make Calls with a Prefix.....	57
Delete Messages.....	57
History	58
Start History.....	58
Display History Data.....	58
Make a Call.....	58
Register	58
Delete	58

TABLE OF CONTENTS

Section 4 Feature Operation

Login	59
Logoff	59
Making Calls	60
Make an External Call	60
Make an Internal Call.....	60
Answering Calls	61
Answer an External Call	61
Answer an Internal Call	61
Holding a Call (using Call Hold)	61
Put a Call on Hold.....	61
Retrieve the Call on Hold.....	61
Holding a Call (using Exclusive Call Hold)	62
Put a Call on Exclusive Call Hold	62
Retrieve the Exclusive Call on Hold	62
Transfer a Call	63
Transfer a Call with Announcement	63
Initiate a Transfer using Extension 200.....	63
Transfer a Call without an Announcement	63
Initiate a Transfer using Extension 200.....	63
Answer a Transferred Call using Extension 210	63

TABLE OF CONTENTS

Last Number Redial	64
One-Touch Speed Calling Keys	64
Program One-Touch Speed Dial Calling Key	64
Verify One-Touch Speed Dial Calling Key.....	64
Station Speed Dialing	65
Register for Station Speed Dialing.....	65
Make a Call Using Station Speed Dialing.....	65
Originating a Voice Call	65
Three/Four-Party Conference	66
Voice Mail	66
Portal Mode	66
Classic Mode.....	66
Preset Answer	66
Set Preset Answer.....	66
Answer to a Call With Preset Answer.....	67
Cancel Preset Answer.....	67
Switching Voice from Handset to Speaker (Listen-Only)	67
Hear Caller's Voice from the Speaker	67
Restart Talking	67
Talking Handsfree	67
Set Handsfree.....	67
Cancel Handsfree.....	67

TABLE OF CONTENTS

Make a Call Handsfree	67
Answer a Call Handsfree.....	67
Call Pickup – Group	68
Call Pickup – Direct	68
Multiline Appearance	68
Answer a Call	69
DND (Do Not Disturb)	69
Set DND	69
Cancel DND.....	69
Save and Repeat a Number	69
Set Save and Repeat	69
Dial using Save and Repeat.....	69
Trunk Queuing – Outgoing	70
Set Trunk Queuing – Outgoing.....	70
When the Trunk is Available	70
Cancel Trunk Queuing – Outgoing.....	70
Call Back	70
Set Call Back	71
When the Busy Terminal Becomes Idle	71
Cancel Call Back	71
Timed Queuing (Outside Line Only)	71
Make/Answer a Call with Call in Progress.....	71

TABLE OF CONTENTS

Station Hunting	72
Step Call	72
Call Waiting	73
Activate Call Waiting.....	73
Answer Call Waiting	73
Executive Override	73
Call Forwarding – Busy Line	74
Set Call Forwarding – Busy Line	74
Verify Call Forwarding – Busy Line	74
Cancel Call Forwarding – Busy Line	74
Call Forwarding – No Answer	75
Set Call Forwarding – No Answer	75
Verify Call Forwarding – No Answer.....	75
Cancel Call Forwarding – No Answer.....	75
Call Forwarding – All Calls	76
Set Call Forwarding – All Calls.....	76
Verify Call Forwarding – All Calls	76
Cancel Call Forwarding – All Calls	76
Call Forwarding – Destination	77
Set Call Forwarding – Destination	77
Cancel Call Forwarding – Destination	77
CID (Caller ID) Call Display	77

TABLE OF CONTENTS

Display Calling Party Information	77
Answer a Voice Call Handsfree	78
Internal Zone Paging With Meet-Me Page	78
Initiate Page (Terminal A).....	78
Answer Page (Terminal B)	78
Boss/Secretary Calling	78
Call Boss from Secretary.....	78
When the Boss Accepts the Call.....	78
Return Message Schedule	79
Set Return Message Schedule.....	79
Cancel Return Message Schedule	79
Whisper Page	80
Using a Headset	80
Make/Answer a Call with a Headset.....	80

Appendix A Menu List

Menu List	A-1
------------------------	------------

Appendix B Input Characters

How to Input Characters	B-1
System/Station Speed Dialing Feature	B-1

TABLE OF CONTENTS

Menu Contents (Password Input)	B-2
Input Mode	B-2
Input Character Tables	B-4
Common/Personal Directory Service Table	B-4
Menu Contents Tables	B-5
Password Input	B-5
USER ID, Password (FTP/HTTPS Server), Folder Name, File Name, Address (URI) Input	B-6
IP Address Input	B-9

Appendix C To Upload an Image

Image Upload Procedure	C-1
PC Connection and Setting	C-1
PC Requirements	C-1
Connection	C-1
Maximum User Program PC Connection	C-2
LAN Setting	C-2
User Programming Setup	C-2
To Upload an Image	C-4

1 Introduction

General

This guide explains how to operate the DT930 (ITK-8TCGX) Touch Panel Model and DT920 Self-Labeling Model (ITK-8LCX) telephones.

CHAPTER 1 INTRODUCTION

Explains the configuration of this guide and contains the following information.

- Face layout
- Keys and Parts
- Icon Display
- Menu List

CHAPTER 2 TERMINAL SETUP

Explains the procedures for setting up the DT930/DT920 telephones.

CHAPTER 3 BASIC OPERATION

Explains the basic operation of DT930/DT920 telephones.

CHAPTER 4 FEATURE OPERATION

Explains operating procedures for various features available with the DT930/DT920 telephones.

Face Layout

**DT920 (ITK-8LCX-1)
Self-Labeling Model**



**DT930 (ITK-8TCGX-1)
Touch Panel Model**



Technical Specifications

Item	ITK-8TCGX-1	ITK-8LCX-1
LCD	4.3 inch TFT, touch panel	3.5 inch TFT
LCD color	Color (16,770,000 colors)	Color (16,770,000 colors)
Programmable Line/Feature Key	–	8 keys
Fixed Feature Key	13 keys (with Menu key and Cursor key)	
Soft key	–	4 keys
Back Light	LCD and digit key (lit for 10 seconds when operating)	
Phone Book	System : Max 90,000 records per system Personal : Max 1,000 records per terminal	
Call History	Outgoing Call: Max 50 records per terminal Incoming Call: Max 50 records per terminal	
XML Browser	Available	
Handsfree	Available (Full duplex), Wideband support	
Headset	Available (HW510 (A10) / HW251N (A10) / W710 (APD-80) / Voyager 5200 / Voyager Legend / Voyager Edge / Jabra Talk 45 <i>Note: EHS headset(HW510 (A10) / HW251N (A10) / W710 (APD-80)) and Bluetooth device (Voyager 5200 / Voyager Legend / Voyager Edge / Jabra Talk 45 and Jabra Speaker 810) cannot be used at the same time. The Bluetooth device takes precedence.</i>	Available (HW510 (A10) / HW251N (A10) / W710 (APD-80)
Speaker	Jabra Speak 810	–

Item	ITK-8TCGX-1	ITK-8LCX-1
LAN Interface	2-port, 10BASE-T/100BASE-TX/1000BASE-T, Full-duplex/Half-duplex, Auto Negotiation/Fixed (Except 1000BASE-T)	
Voice CODEC	G.711, G.729a, G.722	
IP Address Setting	Sets via DHCP server/Sets Statically	
QoS	ToS (IP Precedence, Diffserv)	
VLAN	Tag VLAN (IEEE802.1Q/p), LLDP-MED, DHCP	
Security	IEEE802.1x authentication (EAP-MD5, EAP-TLS), IEEE802.1x authentication support (EAPoL Forwarding) on the PC port via switch at a high hierarchy level, SIP&RTP Encryption, HTTPS (Web Programming/Download), VPN (L2TP/IPsec (IPv4))	
Power Supply	Central Power Supply = IEEE802.3at Type1 (IEEE802.3af compatible) Local Power Supply = AC adapter (Option)	Central Power Supply = IEEE802.3at Type1 (IEEE802.3af compatible)
Power Consumption	Max : About 4.8W, Standby : About 2.3W (without optional connection)	Max : About 3.75W, Standby : About 2.0W (without optional connection)
Download	Boot & Program / Config / Ringing Tone / Music on Hold/ Phone Book / Phone Book list / Wallpaper/ Voice confirmation tone	
Adapter and Accessory (Option)	Wall Mount unit (WM-L) / 60 button DSS/ Numbered Keypad	Wall Mount unit (WM-L) / Numbered Keypad
Dimension (W×D×H)	181(W) x 243(D) x 133(H) *	181(W) x 243(D) x 133(H)
Weight	About 1.0Kg	About 1.0Kg
Environmental	Temperature range = 0° C to 40° C (32° F, to 104° F) Ambient temperature range = -20° C to 60° C (68° F to 140° F) Humidity = 10 to 90% RH (non-condensing)	

* Dimensions are approximate.

Keys and Parts

DT920 (ITK-8LCX)

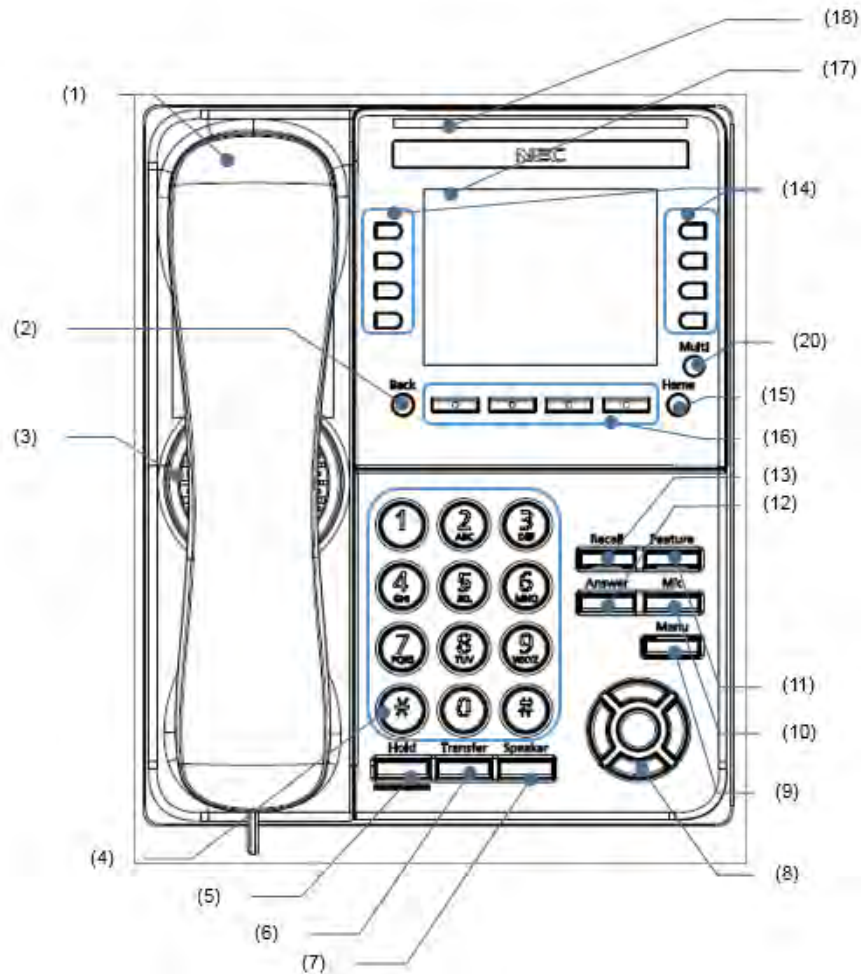

DT930 (ITK-8TCGX)

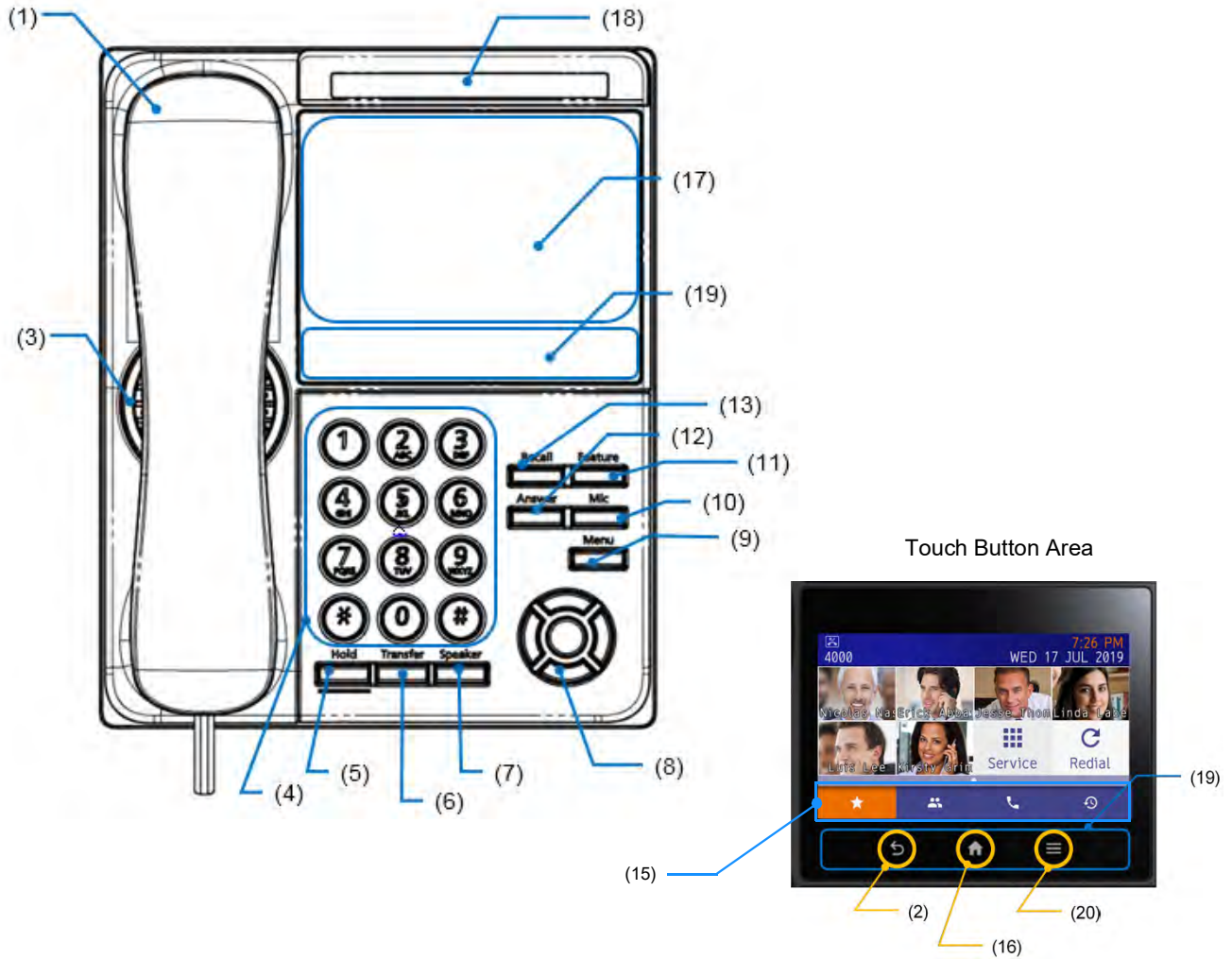

No.	Name	Function
(1)	Handset	Used for sending/receiving voice.
(2)	Back Key	To return to previous window.
(3)	Speaker	Originating a call with handsfree.
(4)	Dial Keypad	Dial the called party number or feature access code.
(5)	Hold key	To place a call on hold.
(6)	Transfer key	Allows the terminal user to transfer established calls to another terminal, without attendant assistance.
(7)	Speaker Key (with light)	To control the built-in speaker which can be used for handsfree dialing or monitoring.
(8)	Cursor Key	<p>Enter key To determine the selected item in the menu. Also, this key is used as cursor-movement key on the local menu of the terminal. This terminal has Shortcut Menu for frequently-used features. Use this key to display the Shortcut Menu (Note: For only classic mode)</p> <p>Volume (UP/DOWN) key Used to adjust speaker/receiver volume, and ringer volume.</p> <p>Right key (Directory) Press this key to open the Directory menu. (Note: For only classic mode)</p> <p>Left key (Redial) Press this key to activate Redial feature. Press Redial and scroll back through numbers that have been dialed. When the desired number is display, press or to activate dialing. (Note: For only Classic Mode)</p>
(9)	Menu Key	To access the menu of terminal.
(10)	Mic Key	To respond handsfree. LED lights during speakerphone operation.
(11)	Feature Key (with light)	To activate features such as terminal setup and to program One-Touch Speed Calling keys.

No.	Name	Function
(12)	Answer Key (with light)	When LED on this key is lit, press this key to answer the incoming call.
(13)	Recall Key	To finish a call and hear the dial tone to make an another call.
(14)	Programmable Keys (with light)	These keys can be programmed as Flexible line key/Programmable feature key by system administrator.
(15)	Home Key	To go back to the Home window.
(16)	Soft keys	The feature name is shown at the bottom of the LCD. The appropriate feature key is displayed on the screen according to the call handling process.
(17)	LCD	To display date or dialed number, etc.
(18)	Call Indicator Lamp	The lamp at the top corner of display flashes when a call terminates to the terminal and when you use voice mail. the lamp lights when a message has been left.
(19)	Touch Button Area	The touch screen button area on the telephone. This area includes three buttons; the Back Key (2), the Home Key (16) and the Multi Key (20).
(20)	Multi Key	To display the application switch screen.

Telephone Basics

Telephone Startup

The telephone displays the screen that is set as the home screen. The home screen can be set to either the Favorite screen/Call screen/Line screen. In addition, when the home URL has been set, the telephone displays the screen obtained from the URL.

For details, refer to [Screen When the Phone Starts](#).

Favorite Screen

You can easily make calls by using registered shortcuts of an extension or outside line.

Following explains about each display area.

When the dial button is pressed or an incoming call is received, the Call screen is automatically displayed for telephone operations.



You can also manually return to the Favorite screen to continue the operation. However, the Hold button cannot be used. Switch to the Call screen when operating the phone.

Display Example for DT930 (Touch Panel Model)

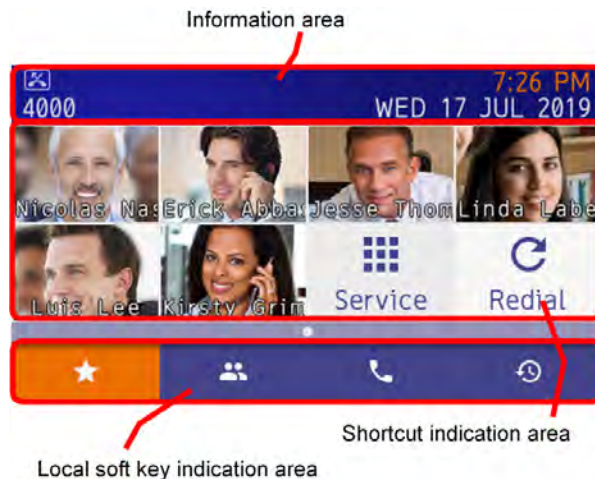

This is an example of a display when shortcuts are registered.

Display Example for DT920 (Self Labeling Model)

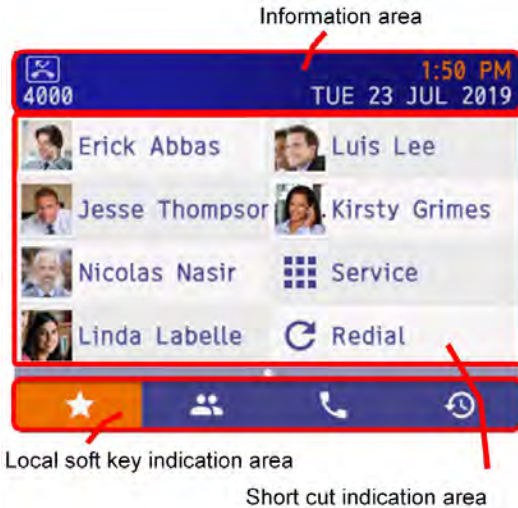

Home URL

When the Home URL is set to XML content, the start screen display is different.

Information Area

This section explains the information area.

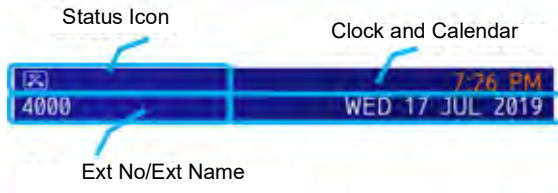

Status Icon

When a voice mail recording is received, an icon is displayed in the information area. This allows you to quickly identify that you have unread voice mail messages.

The following lists the icons and what they indicate.



Icon	Icon Name	Description
	Missed Call	Indicates a missed call. The arrival time of the call is provided.
	Voice Mail Arrival	Indicates a voice mail message has been left in your mailbox.
	Sound Coding	Indicates a sound has been encrypted.
	Call Recording	When Call Recording is activated, one of the status icons display the status of the call recording.
	Power Save	Indicates the telephone is in power save mode.
	Headset	Displays when the headset is in use.



Power Save Icon

Power save mode is the initial system setting.
For details, contact your System Administrator.

Ext No./Ext Name

“Ext no.” is the extension number assigned to the telephone.

If the SV9100 Internal Extension List is downloaded, “Ext name” is displayed from the SV9100 Internal Extension List.

“Ext no.” and “Ext name” are indicated alternately every two seconds.



If the extension name or number is too long for the display area, the excess text or numbers will be truncated.

Call Screen

This area consists of a calendar and clock.

The default display format follows setting of the system.

It is possible to change the format in the user settings.

Refer to [Setting Calendar Format on page 27](#).

Local Softkey Indication

The following local softkeys are indicated.

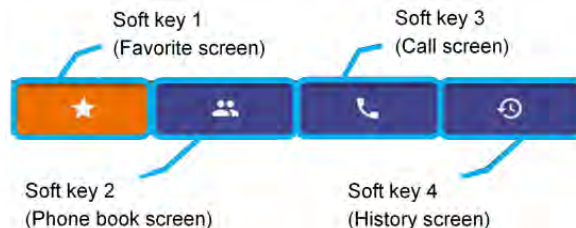

Local Softkey 1

Go to Favorite screen.

Local Softkey 2

Go to Personal Phone Book or a System Phone Book.

Local Softkey 3

Go to call screen. Use this feature when you make a call or system service, etc.

Local Softkey 4

View call history data.

Call Screen

This screen is displayed by pressing local softkey 3 at the Favorite screen.

When pressing a digit key or function key, the following screen is displayed.

You can make a call, talk, and use system service using this screen. For information regarding system service operation, refer to [Section 3 Basic Operation](#).

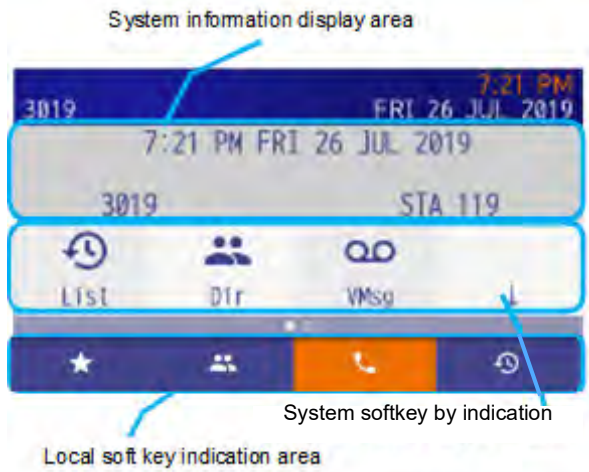

System Information Area

A character information from a system is indicated.

System Softkey Area

The soft keys that are provided by the system are displayed in this area. It cannot be selected by pressing local soft key.

How to select system soft key

DT930 (Touch Panel model)
Tap the system soft key. Only when the item is selected, the orange focus will be displayed until the screen changes to the next screen.

DT920 (Self Labeling model)
Press programmable key located on the side of each soft key.

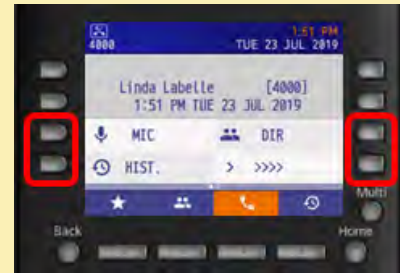

Local Softkey Area

It is possible to go to phone book screen or history screen like a favorite screen.

Start the Call Screen

Use the following procedure for displaying the Call screen.

When a screen other than the Call screen / Line screen is displayed and the Call screen is activated with a display method with a circle in the auto end column in the table below, the system is automatically set by on-hooking or abandoning the call. Exit the screen and return to the original screen. For details, see [To Close Call Screen Automatically](#).

Operations	Auto Close
When pressing local soft key that is assigned call screen icon.	
When there is an incoming call to the terminal (without assigning to the line key).	<input type="radio"/>
When you lift the handset.	<input type="radio"/>
When the terminal receives instructions from XML application server.	<input type="radio"/>
When a pop-up button on the XML application is pressed.	
When the terminal receives instructions from a system.	

To Close Call Screen Automatically

If the system screen is displayed in a way that is subject to automatic termination, placing the handset on-hook or abandoning the call will return you to the screen before the call started.

However, automatic termination does not occur in the following cases.

Does Not Close Automatically
When a menu button is pressed and the XML application is selected by the application change screen during a call screen.
When the terminal receives instructions from an XML application server.
When a soft key other than soft key 3 is pressed, while the system screen is displayed to switch to another screen.

Line Screen

You can go to line screen by moving page from call screen.

This screen shows line key information registered in the system.

On touch panel terminals, the line key status is displayed with the line key lamp icon.

System information is displayed on the second and third lines of the call screen.



Line screen is available for DT930 (Touch Panel Model), DT920 (Self-Labeling model)

Double height characters display will not be performed on the line screen.

Count Lines on the Call Screen

Count lines on the call screen

First line

Second line

Third line

4000

7:27 PM WED 17 JUL 2019

Linda Labelle [4000]

7:27 PM WE 17 JUL 2019

MIC DIR HIST. >>>

☆ [Call] [End Call]



How to Transfer to next line key page

*DT930 (Touch Panel Model):
Swipe or Cursor operation.*

*DT920(Self-Labeling Model):
Cursor operation only.*

Display Example for DT930 (ITK-8TCGX – Touch Panel Model)





Display Example for DT920 (ITK-8LCX –

Self-Labeling Model)



The line key status can be distinguished by line key lamp (on/off/flash) or line key lamp icon display. The following table shows the line key lamp/lamp icon indications by each terminal status.

Line Key Lamp	Line Key Lamp Icon	Example of Terminal Status
Off	Not Displayed	Idle State
Green Steady		During an Outgoing Set/ Cancel DND
Red Flashing		Incoming call is arriving
Green Flashing		Holding a call
Green Flashing		Exclusive hold

Line Key Lamp	Line Key Lamp Icon	Example of Terminal Status
Red Steady		The other terminal is talking on line The other terminal sets exclusive hold
Red Flashing		The other terminal is holding a call
Green Flashing		Recall from held call after the predetermined time

A number of line key page is at most 4. This depends on the license. For details, please contact the system administrator.



 This line key is a required system setting at initial installation. For details, contact the system administrator.

Phone Book

There are two patterns you can use to make calls using the Phone Book. One is “Personal Phone Book”; the data is saved in each phone. The other is System Phone Book “Directory (Common and Person)”; the data is saved in the system.

To use the Personal Phone Book, press the local softkey **2** at the Favorite screen or Call screen.

To use the System Phone Book, press the system softkey **2** (Dir) on the Call screen.

 The choice of whether a personal phone book is used is established on the system side. Check with your system administrator for details.

You can search or make calls to a person registered in the Phone Book.

Example of a Personal Phone Book:

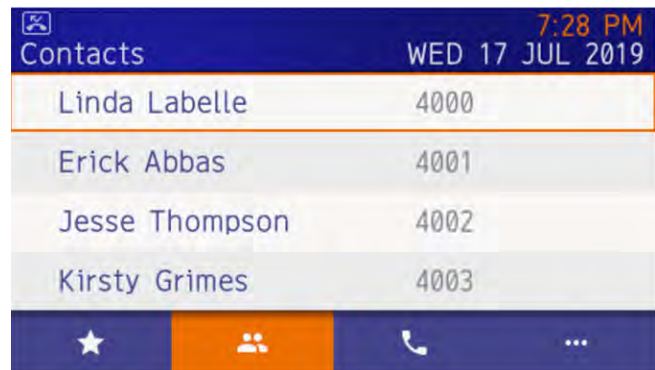

Refer to [Section 3 Basic Operation, Personal Phone Book on page 56](#) for details about the operating method.

Example of a System Phone Book:

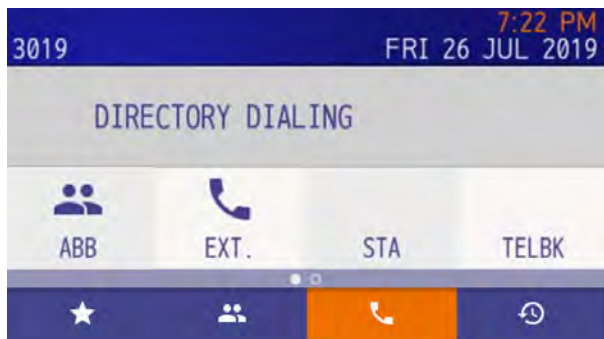

Refer to [Section 3 Basic Operation, Phone Book on page 15](#) for details about the operating method.

Call History

Outgoing and incoming calls are displayed.

To display the history, press key **4** (History) on the Favorite screen or System screen.

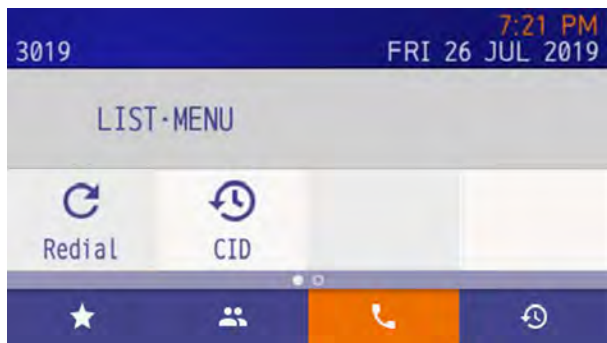

Refer to [Call History on page 16](#) for details about the operating method.

Menu and Setting

You can change the telephone settings from the Setting menu. To access the Setting menu, press the Menu key.



To change the telephone functions, press local softkey **4** to access the Setting menu.

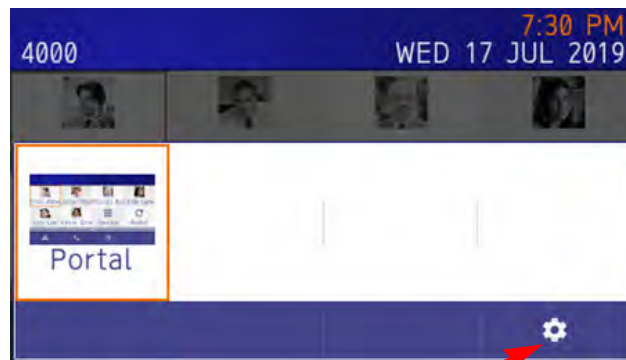

Setting menu

Refer to [Section 2 Terminal Setup](#) for details about the setting contents.

Installation

Attaching Handset

- (1) Install the modular plug (attached to the curl cord of the handset) into the handset connector at the back of terminal. Push until it snaps into place.
- (2) Lead the Handset cable through the applicable groove.

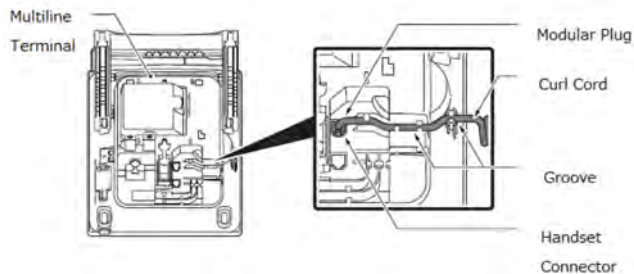

- (2) Install the Line Cord in the groove as shown in the following diagram.

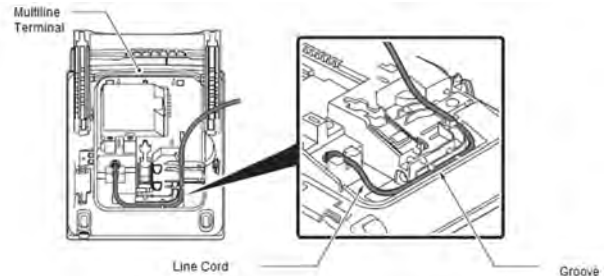

Connect the Line Cord

Line Cord Connection DT930

- (1) Install the modular plug of the line cord into the Line Connector at the back of terminal. Push until it snaps into place.

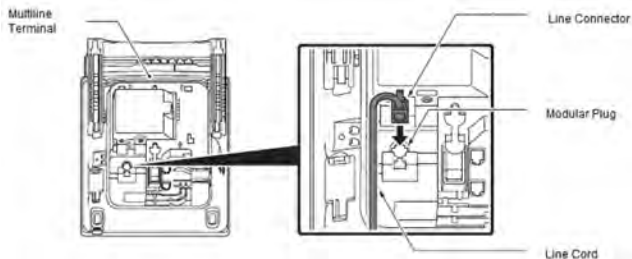

- (3) Turn the terminal over and place it so the line cord can be passed through the groove between the tilt legs.

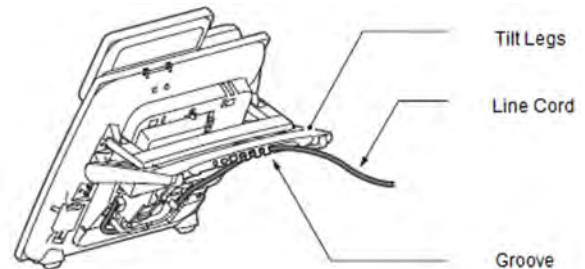

Attach the Directory Card

A directory card can be attached to multiline telephone. The directory card can be used to record often dialed numbers or other important information.



The Directory Card is optional.

- (1) Insert the holder into the holder socket on the back of the multiline telephone.

- (2) A protective sheet is attached to the surface of the cover to prevent scratches. Peel off before attaching to the holder.
- (3) Insert the Directory Card into the cover and attach it to the holder.

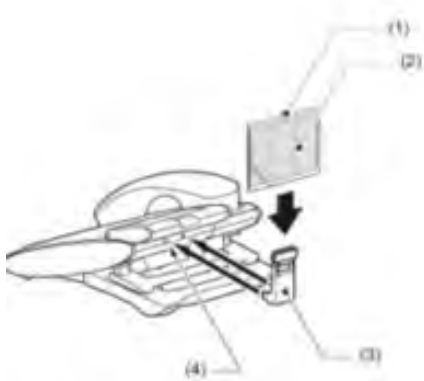

- (1) Plastic Cover
- (2) Directory Cover
- (3) Directory Card Holder
- (4) Groove

Attach or Remove Faceplate and DESI Printer Sheet

Removing Faceplate and DESI Printer Sheet

Remove DESI printer sheet using the following:

- (1) Use the small notch at the lower right corner of the terminal to lift the faceplate up.
- (2) Remove the faceplate.

- (3) Remove the DESI Printer Sheet.

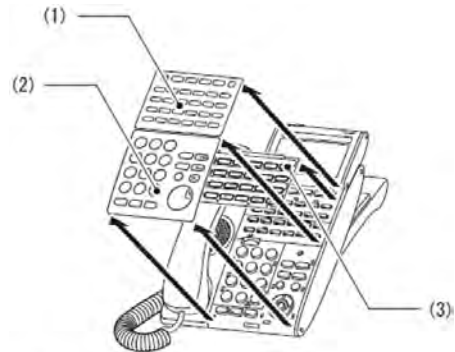

- (1) Line Key Panel
- (2) Numbered Keypad Panel
- (3) DESI Printer Sheet

Attaching Faceplate and DESI Printer Sheet

- (1) After replacing the DESI Printer Sheet on the terminal, attach the faceplate.
- (2) At each corner, press the locking pin back into place (see the diagram above).



Ensure the faceplate is attached securely. If it is loose, the terminal may not operate correctly if a key is being pressed by the faceplate.

Connect the Headset

For DT900 series, three types of headset are available; wired headset, EHS headset, and Bluetooth headset (DT930 Touch Panel Model only). This procedure explains about connecting wired headset and EHS headset cable.

- (1) Plug the modular plug of headset into the HEADSET connector on the bottom of terminal.

- (2) Fit the headset cord into the groove.

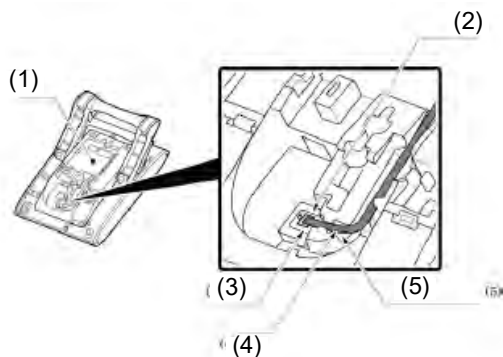

- (1) Terminal
- (2) Headset Connector
- (3) Modular Plug
- (4) Cord
- (5) Groove



Refer to *Section 2 Terminal Setup, Making/ Answering Calls with a Headset* on page 40.



For the headset that is supported, please contact the NEC's dealer or NEC.



The headset, which can be connected to the telephone, is "HW510 (A10)/HW251N (A10) (manufactured by Plantronics).

Connect LAN Cable

Confirm the location of the LAN connector at the back of the multiline terminal. Then connect the multiline terminal using the following steps.

- (1) Connect the LAN Network cable to the LAN (=) connector and plug the other end of the cable into the PoE switch.
- (2) The IP terminal has a Switching HUB to connect a PC to the LAN Network. Connect the 10 Base-T/100 Base-TX/1000 Base-T straight cable used for this connection to the PC(x) connector and to the PC.

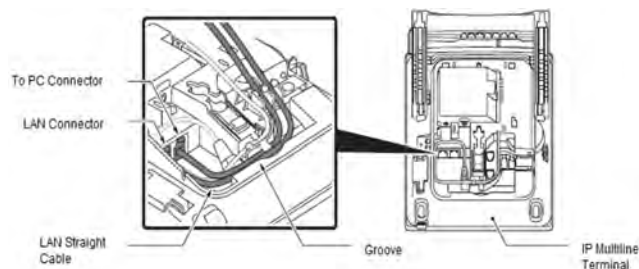

When using the PC port with a local power supply, depending on the LAN cable connector housing, the LAN cable connector may not fit. Remove the outer plastic covering from the LAN cable connector; or use the LAN cable with a thin connector.



When using the ITK-8TCGX, you can use a local power supply by installing the AC adapter as shown in the following diagram.

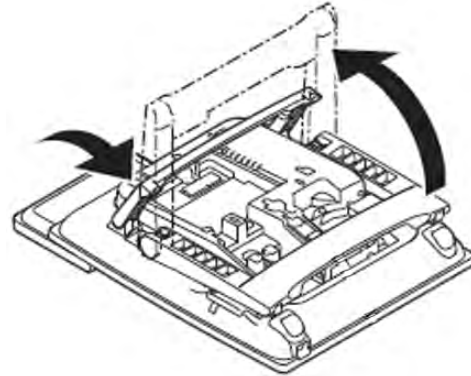
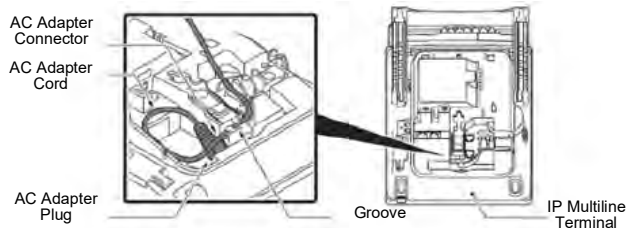

Adjust Angle of Tilt Legs

Raising the Height of the Tilt Legs

The height can be adjusted by moving the legs, which are attached to the bottom of the terminal.

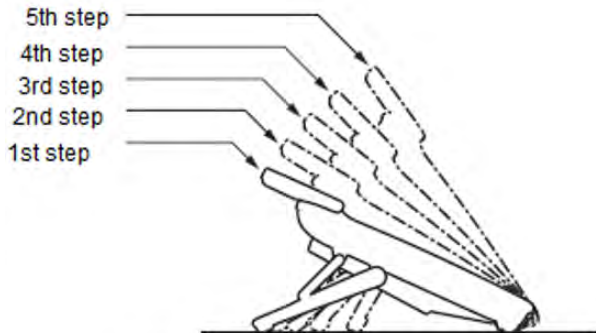

DT500/DT900 Series Multiline Terminal

- (1) Turn the terminal over (key side down).
- (2) Adjust the legs to the desired height (upward to raise the height and downward to lower the height).

- (3) Turn the terminal over (key side up).

Lowering the Tilt Legs

- (1) Turn the terminal over (key side down).
- (2) Adjust the legs to the desired height.

Wall Mounting

Wall mounting of the terminal is installed with an optional Wall Mount Unit.

Required Space

Before drilling, use the template shown in the following figure for spacing requirements.

When mounting the ITX-8LCX/ITX-8TCGX:

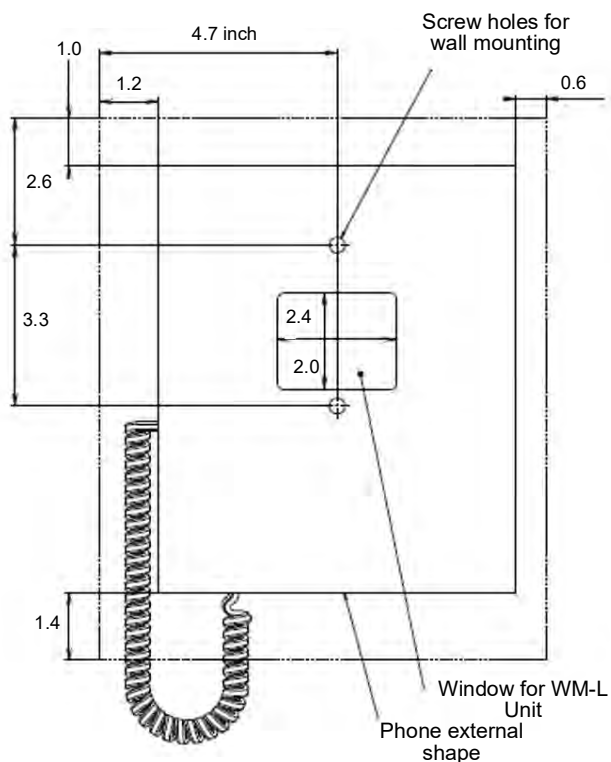

Wall Mount the Terminal

This section shows the installation procedure for wall mounting the terminal.

- (1) Turn terminal over (key side down).
- (2) Remove the hanger hook from the terminal, and then reverse it and reinsert it to the terminal.

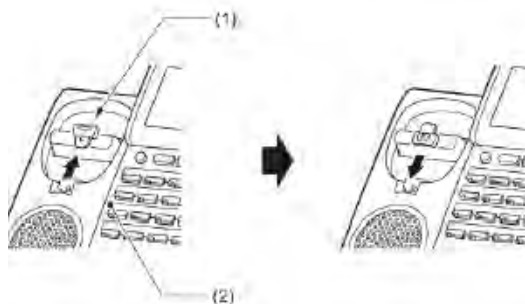

- (1) Hanger Hook
- (2) Terminal

- (3) Turn the terminal over, and then spread the tilt legs.
- (4) Install the Wall Mount Unit on the wall or on the wall plate using one of the following procedures.

Mount Terminal on Wall using Wall Mount Unit

Attach the Wall Mount Unit to the wall using six screws or using two wall mounted screws.

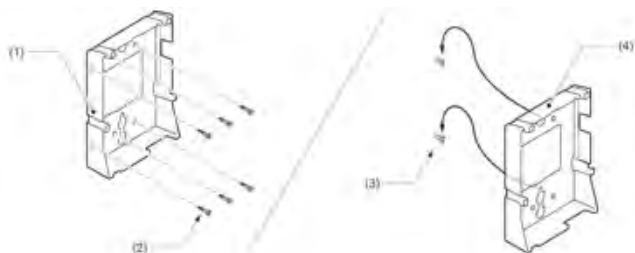

- (1) Wall Mount Unit
- (2) Screws (Included Parts)
- (3) Screws (Locally Supplied)
- (4) Wall Mount Unit

Mount Terminal on Wall Plate using Wall Mount Unit

Locate the screw holes on the base and hang the cover over the screws on the wall plate.

- (5) Connect the LAN Cable. Refer to [Connect LAN Cable on page 19](#).
- (6) Align the four cutouts on the bottom of the terminal with the tabs on the Wall Mount Unit.
- (7) Plug one end of the line cord into the wall receptacle.

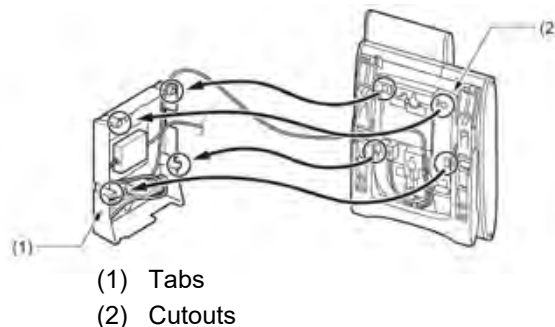

- (1) Tabs
- (2) Cutouts

2 Terminal Setup

This chapter describes basic operating procedures for the terminal. Various terminal operations such as display, sounds, password and backup and restore are available.

Adjusting Volumes



You can only adjust the volume on the Call screen and Line screen.



When setting up the terminal, the softkey indicates the local softkey.

If the Back/Exit button is pressed while the Terminal Setting menu is displayed, the Favorite screen is displayed regardless of Home screen settings.

Below is an example of the display when volumes are being adjusted.

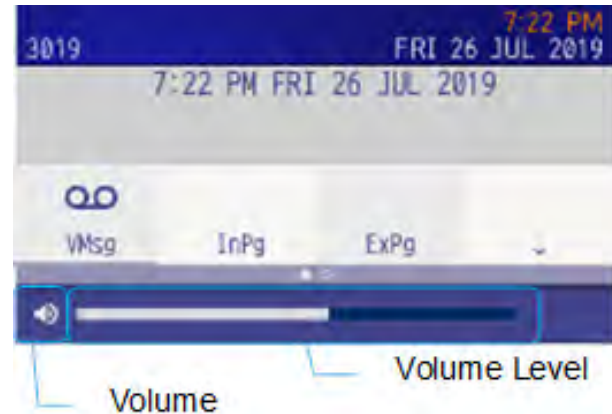

Adjust Handset Receiver Volume

It is possible to adjust the volume level of handset receiver during a call in progress while using handset.

To adjust the volume, press the **UP** or **DOWN** key while off-hook or during a call using the handset.



Adjust Speaker Volume

It is possible to adjust the volume level of speaker during a call in progress using speaker. To adjust the volume, press **UP** or **DOWN** key during speaker phone operation or during a call using the speaker.

Adjust Ringer Tone

It is possible to adjust the volume level of ringer tone during incoming call arrival.

To adjust the volume, press **UP** or **DOWN** while the telephone is ringing.

Setting Headset Ringing

Following explains how to enable/disable headset ringing.



This feature is required for both terminal and system settings at initial installation. For details, contact the system administrator.

- (1) Display the Menu screen, and select **Settings**.
- (2) Select **1** (User Setting).
- (3) Select **1** (Incoming Call).
- (4) Select **2** (Headset Ring).
- (5) Select whether to ring the headset ringer.

Setting Ringer Tone

This section explains how to set a ringer tone.

Distinctive Ringing Patterns to Distinguish Internal and External Incoming Calls – Provided

When distinctive ringing patterns, which allow you to distinguish internal and external incoming calls, are provided you can leave the **Ring Tone** setting to **Automatic** (default setting).



Use each default ringer tone for both external and internal incoming calls.

Ringling pattern is programmable on a system basis.

For details, contact the system administrator.

Distinctive Ringing Patterns to Distinguish Internal and External Incoming Calls – Not Provided

When distinctive ringing patterns, which allow you to distinguish internal and external incoming calls, are *not* provided you can set ringer tone using the steps listed below.

- (1) Display the Menu screen, and select **Settings**.
- (2) Select **1** (User Setting).
- (3) Select **1** (Incoming Call).
- (4) Select **3** (Ring Tone).
- (5) Select **2** (Internal Call).



*Do not select **1** (External Call).*



*Ringling Tone , which is selected in **2** (Internal Call), is applied to both external and internal incoming calls.*

- (6) Select the desired tone type.

NO.	MENU ITEM	FREQUENCY (Hz) 1st	FREQUENCY (Hz) 2nd	REMARKS
0	Automatic	-	-	-
1	Tone Type 1	520	660	16Hz Modulation
2	Tone Type 2	520	660	8Hz Modulation
3	Tone Type 3	1400	1100	Door Phone
4	Tone Type 4	1100	1100	No modulation
5	Tone Type 5	540	540	No modulation
6	Tone Type 6	1100	1400	16Hz modulation
7	Tone Type 7	660	760	16Hz modulation
8	Tone Type 8	1100	1100	Envelope

NO.	MENU ITEM	FREQUENCY (Hz) 1st	FREQUENCY (Hz) 2nd	REMARKS
9	Tone Type 9	—	—	Door Phone Melody
10	Tone Type 10	—	—	Melody 1
11	Tone Type 11	—	—	Melody 2
12	Tone Type 12	—	—	Melody 3
13	Tone Type 13	—	—	Melody 4
14	Tone Type 14	—	—	Melody 5
15	Music Ring 1	—	—	C-Major Scale Ringtone
16	Music Ring 2	—	—	Canon
17	Music Ring 3	—	—	Turkish March



Tone Type 1 to Tone Type 8:

In the preview function, each ringer tone sounds continuously. However when 0 (Automatic) is selected, each ringer pattern of internal and external incoming calls is determined by the initial system settings.

For details, contact the system administrator.



*When selecting **Automatic**, the preview function does not operate.*

Setting by Feature key it becomes effective.



*The **Music Ring 1/2/3** have been downloaded at factory to terminal firmware 2.1.0.0 or later.*

*When you use ring tone music source other than **Music Ring 1/2/3**, please download the other music file.*

Setting Illumination Pattern for Call Indicator Lamp

The following explains how to set the illumination pattern (color of Call Indicator Lamp).

- (1) Display the Menu screen, and select "Settings"
- (2) Select **1** (User Setting).
- (3) Select **1** (Incoming Call).
- (4) Select **4** (Illumination).
- (5) Select **1** (External Call) or **2** (Internal Call).
- (6) Select a desired illumination pattern.

Enabling/Disabling RTP Alarm

The following procedure explains how to enable/disable RTP Alarm. The RTP Alarm tone allows the terminal user to be notified that the voice packet is not received in a certain period of time because of the network delay, etc.

- (1) Display the Menu screen and select **Settings**.
- (2) Select **1** (User Setting).
- (3) Select **2** (Talk).
- (4) Select **1** (RTP Alarm).
- (5) Select whether to ring the RTP Alarm.



*If the **0** (Automatic) is selected, this feature is activated in accordance with the system data setting. If it is not specified by the system data this feature is in effect (RTP Alarm = ON).*

For details, contact the system administrator.

Enabling/Disabling DTMF Tone

The following procedure explains how to set whether a DTMF tone is played when the other party presses a button on their telephone during a call.

- (1) Display the Menu screen and select **Settings**.
- (2) Select **1** (User Setting).
- (3) Select **2** (Talk).
- (4) Select **2** (DTMF Tone).
- (5) Select whether the DTMF tone is played.



*If the **0** (Automatic) is selected, this feature is activated in accordance with the system data setting. If it is not specified by the system data this feature is in effect (RTP Alarm = ON).*

For details, contact the system administrator.

Setting Key Touch Tone

Following explains how to set Key Touch Tone. Key Touch Tone is a tone generated when the digit keys are pressed while terminal is off-hook.

- (1) Display the Menu screen and select **Settings**.
- (2) Select **1** (User Setting).
- (3) Select **2** (Talk).
- (4) Select **3** (Key Touch Tone).
- (5) Select desired mode of Key Touch Tone.



*If **0** (Automatic) is selected, this feature is activated in accordance with the system data setting.*

For details, contact the system administrator.

Setting Music On Hold

The following procedure explains how to set Music on Hold to be heard by terminal user.

- (1) Display the Menu screen and select **Settings**.
- (2) Select **1** (User Setting).
- (3) Select **2** (Talk).
- (4) Select **4** (Hold Music).
- (5) Select desired Music on Hold.



*When selecting **Download**, the Music on Hold file must be downloaded in advance. If there is no downloaded file, you hear no tone in the preview function (in actual operating conditions, “Minuet” is automatically applied).*

Setting the Prefix

The following procedure explains how to set the prefix number.

- (1) Display the Menu screen and select **Settings**.
- (2) Select **1** (User Setting).
- (3) Select **2** (Talk).
- (4) Select **5** (Prefix).
- (5) Select the prefix number you want to register.
- (6) Enter the prefix number.



Up to 10 digits can be registered.

Setting Calendar Format

The following procedure explains how to set the calendar format that is displayed on the telephone.

- (1) Display the Menu screen and select **Settings**.
- (2) Select **1** (User Setting).
- (3) Select **3** (Display).
- (4) Select **1** (Calendar Format).
- (5) Select **1** (Calendar Format).

(6) Select desired format for the calendar.

No.	Calendar Type	12-Hour Clock
1	Type 1	MON 3 JUN 2019 3:13 PM.
2	Type 2	3 JUN MON 3:13 PM.
3	Type 3	JUN 3 MON 3:13 PM.
4	Type 4	6-3 MON 3:13 PM.
5	Type 5	MON 3 JUNE 3:13 PM.

No.	Calendar Type	24-Hour Clock
1	Type 1	MON 3 JUN 2019 15:13
2	Type 2	3 JUN MON 15:13
3	Type 3	JUN 3 MON 15:13
4	Type 4	6-3 MON 15:13
5	Type 5	MON 3 JUNE 15:13

Setting Time Format

The following procedure explains how to set the time format that is displayed on the telephone.

- (1) Display the Menu screen and select **Settings**.
- (2) Select **1** (User Setting).
- (3) Select **3** (Display).
- (4) Select **1** (Calendar Format).
- (5) Select **2** (Time Format).

Select either 12-hour or 24-hour format for the time. Refer to the chart above for the available time formats.



*If set to **0** (Automatic), the format depends on the system setting.*

For details contact your system administrator.

Enabling/Disabling Volume Level Display

The following procedure indicates whether to display the following volume levels: handset receiver volume, speaker volume, ringer tone volume and LCD contrast volume.

- (1) Display the Menu screen and select **Settings**.
- (2) Select **1** (User Setting).
- (3) Select **3** (Display).
- (4) Select **2** (Local Volume).
- (5) Select whether to display the volume level.



*If set to **0** (Automatic), **2** (Enable) is applied.*

Setting Screen Saver

This procedure explains how to set the Screen Saver when the terminal is idle for a certain period of time.

- (1) Display the Menu screen and select **Settings**.
- (2) Select **1** (User Setting).
- (3) Select **3** (Display).
- (4) Select **3** (Screen Saver).
- (5) Select **1** (Screen Saver Mode).

- (6) Select whether to launch the Screen Saver.
- (7) Select **2** (Wait Time).
- (8) Enter the **Wait Time**.

Setting Brightness of LCD Back Light

The following procedure explains how to set the brightness of the LCD back light.

- (1) Display the Menu screen and select **Settings**.
- (2) Select **1** (User Setting).
- (3) Select **3** (Display).
- (4) Select **4** (Back Light).
- (5) Select a desired brightness.



*The lighting time of back light is set by system data setting at initial installation (initial setting is 10 seconds).
For details, contact the system administrator.*

Enabling/Disabling LCD Back Light Fade Control

The following procedure explains how to set Back light Fade Control. When you set Back light Fade Control as “Enable”, the LCD is smoothly turned On/Off.

- (1) Display the Menu screen and select **Settings**.
- (2) Select **1** (User Setting).
- (3) Select **3** (Display).
- (4) Select **6** (Advanced).



*Select **7** (Advanced) when the GUI is in Classic Mode.*

- (5) Select **2** (Backlight Fade Control).
- (6) Select whether to turn On/Off the LCD smoothly.

Changing Font Size

This procedure explains how to change the font size displayed on the LCD.



This function is available when the GUI is in Classic mode.

- (1) Display the Menu screen and select **Settings**.
- (2) Select **1** (User Setting).
- (3) Select **3** (Display).
- (4) Select **5** (Font Size).
- (5) Select **Font Size**.

Setting a Language

This procedure explains how to change the language displayed on the LCD.



*The language is set using the system data setting at initial installation. Therefore, there is no need to change the language from default setting (0- Automatic) on the terminal.
For details, contact the system administrator.*

Selecting Wallpaper

This procedure explains how to set wallpaper.



This function is available when the GUI is in Classic mode.

- (1) Display the Menu screen and select **Settings**.
- (2) Select **1** (User Setting).
- (3) Select **3** (Display).
- (4) Select **7** (Advanced).
- (5) Select **1** (Wallpaper).
- (6) Select **How to display the wallpaper**.



*When selecting **2** (Download), the wallpaper file must be downloaded in advance. If there is no downloaded file, the **1** (Default wallpaper) is effected.*

For the procedure of downloading a wallpaper file, please refer to [Downloading a File on page 35](#).

Setting Font Colors

This procedure explains how to set the character color displayed on the LCD.



This function is available when the GUI is in Classic mode.



This setting is applied to the "1-3" line of LCD 4-Line Display. (Softkey characters are not applied.)

- (1) Display the Menu screen and select **Settings**.
- (2) Select **1** (User Setting).
- (3) Select **3** (Display).
- (4) Select **7** (Advanced).
- (5) Select **2** (Font Color).
- (6) Select a desired color.

NO.	ITE	RGB Value
1	Color1	0x000000
2	Color2	0x000080
3	Color3	0x0000FF
4	Color4	0x008000
5	Color5	0x008080
6	Color6	0x00FF00
7	Color7	0x00FFFF
8	Color8	0x800000
9	Color9	0x800080
10	Color10	0x808000
11	Color11	0xA0A0A0
12	Color12	0xC0C0C0
13	Color13	0xFF0000
14	Color14	0xFF00FF
15	Color15	0xFFFF00
16	Color16	0xFFFFFF

Turning Display Off

The **Turn Off Display** option works after the terminal is idle for a certain period of time. This procedure explains how to set **Turn Off Display**.

- (1) Display the Menu screen and select **Settings**.
- (2) Select **1** (User Setting).
- (3) Select **3** (Display).
- (4) Select **6** (Advanced).



Select **6** (Advanced) when using Portal Mode.
Select **7** (Advanced) when using Classic Mode.

- (5) Select **1** (Turn Off Display).



Select **1** (Turn Off Display) when using Portal Mode.
Select **3** (Turn Off Display) when using Classic Mode.

- (6) Select **1** "Turn Off Display Mode".
- (7) Select whether to launch Turn Off Display.



When **3** (App priority) is selected, the Screen Saver works by the external application. The LCD turns off when the terminal receives the instruction to turn off LCD from the external application while the Screen Saver is running.



The Screen Saver can be set as the external application.
For details, contact the system administrator.

- (8) Select **2** (Wait Time).

- (9) Enter the Wait time.



The [Wait Time] is ineffective when [Turn Off Mode] has been set as **3** (App priority) and the terminal does not receive the instruction to turn off the display from the external application.

Changing the Theme

The following procedure explains how to change theme color of the screen.



This function is **not** available when the GUI is in Classic mode.

- (1) Display the Menu screen and select **Settings**.
- (2) Select **1** (User Setting).
- (3) Select **3** (Display).
- (4) Select **7** (Portal Mode Settings).
- (5) Select **2** (Change Theme).
- (6) Select desired theme.

This is an example of the display when theme is Black.

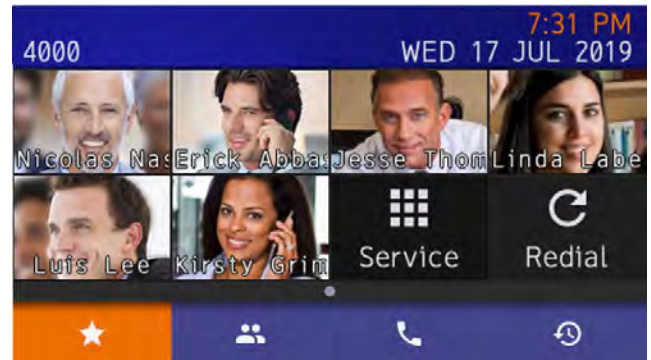

Enabling/Disabling Animation

This procedure explains how to set whether to enable animation when the screen changes.



Animation is available for DT930 (Touch panel model).

- (1) Display the Menu screen and select **Settings**.
- (2) Select **1** (User Setting).
- (3) Select **3** (Display).
- (4) Select **7** (Portal Mode Setting).
- (5) Select **3** (Animation).
- (6) Select whether to enable animation.

Screen When the Phone Starts

The screen when the phone starts or home key is pressed depends on settings. This section explains the settings that affect the screen display.

Setting Home Screen

The following explains how to set a screen that will be displayed when the phone has started up or the Home key is pressed.

- (1) Display the **Menu** screen, select **Settings**.
- (2) Select **1** **User Settings**.
- (3) Select **3** **Display**.
- (4) Select **7** **Portal Mode Settings**.
- (5) Select **4** **Home Screen Setting**.

- (6) Select a desired screen.



*The default setting is **Automatic**.*

Register a Home URL

The screen display is not only set by the **Home screen settings**, but the phone can also be set to access the XML application right after start up by registering the address information of the application as a Home URL.

This section explains how to display the menu screen and an example of the screen display when the phone starts.



Registering the home URL is performed during the initial setting stage. For details, contact your administrator.

Portal Screen



Portal screen is home (entrance) of the phone. When multiple XML applications are used, the XML application specified as the home URL will be the portal screen, and be the entrance to access different XML applications.

If there is not a registration of the home URL, the Favorite screen is assigned as the portal screen.

To Start Up the Phone

The phone automatically accesses the Home URL and displays the received XML application.



The following XML application image is an example and depends on the application used.



Press the **Menu** button to display the menu screen.

The screen that is displayed as the portal icon at that time is the XML application screen registered as the Home URL.



“Portal” is usually displayed as an application name registered by the external application.

When the home URL has been registered, the home URL screen is displayed instead of the favorite screen when local soft key 1 is pressed.

When the Home URL is registered the following occurs in Home settings:

Set to Automatic

The screen obtained from the Home URL is displayed.

Set to Favorite Screen

The screen obtained from the Home URL is displayed.

Set to Call Screen

The call screen is displayed. The favorite screen cannot be displayed because the Home URL is displayed as the portal screen.

Changing the Password

This procedure explains how to change an existing password. The password is used for the following operations:

To lock/unlock the terminal.

To reset the terminal settings

- (1) Display the Menu screen and select **Settings**.
- (2) Select **1** (User Setting).
- (3) Select **4** (Change Password).

- (4) Enter the old password.



The initial password is “0000”. When changing the password for the first time, enter “0000” as the old password. In order to ensure the security and avoid the unauthorized use, please be sure to change the password at the time of initial use.

The password should be difficult to guess from a third party. And it should be changed regularly to keep security level.

- (5) Enter the new password.



Up to 32 digits can be set as a password.

- (6) Enter the new password again.

- (7) Press the **OK** softkey.

The password entry completes successfully.

If the password entry fails, an error message is displayed.



If you have forgotten your password, contact your system administrator.

Setting Security

This option is grayed out, it is not available.

Setting Usability

This procedure explains how to set the Pop-up operation of Home key.



This function is available when GUI mode is classic.

- (1) Display the Menu screen and select **Settings**.
- (2) Select **1** (User Setting).
- (3) Select **7** (Usability).
- (4) Select **1** (Help Key Mode).
- (5) Select a desired mode of Help key.

Resetting Terminal Settings

This procedure explains how to clear the personal data on the telephone.

- (1) Display the Menu screen and select **Settings**.
- (2) Select **1** (User Setting).
- (3) Select **0** (Setting Reset).
- (4) Enter the password.
- (5) Press the **Enter** key or the **OK** softkey.

If the password entry fails, an error message is displayed. When it fails, press the **Enter** key or **OK** softkey and retry the password entry.



If you have forgotten your password, contact your system administrator.

Downloading a File

You can download files for Music on Hold, Ringer Tone and Wallpaper. When downloading these files, the terminal needs to be connected to the network that has FTP, TFTP or HTTPS server.



For details regarding the DTP/TFTP or HTTPS service, contact your system administrator.

- (1) Display the Menu screen and select **Settings**.
- (2) Select **1** (User Setting).
- (3) Select **2** (Download).
- (4) Select the Protocol type of the server where the download files are stored.
- (5) According to FTP, TFTP or HTTPS that you selected in the [Protocol] screen, proceed to the following steps.
 - When 1 (FTP) is selected here, go to step 7*
 - When 2 (TFTP) is selected here, go to step 9*
 - When 3 (HTTPS) is selected here, go to step 7*
- (6) Select **4** (Account Settings).
- (7) Select **1** (User ID).
- (8) Enter a User ID with digit keys.



Refer to [Appendix B Input Characters](#) for entering instructions for entering characters.

- (9) Select **3** (Folder).
- (10) Enter the folder name where the download file is stored.



Refer to [Appendix B Input Characters](#) for entering instructions for entering characters.

- (11) Press the Left key or Softkey (Back).
- (12) Select **2** (Download Address).
- (13) Enter an IP address/address (URI) of the FTP/TFTP/HTTPS server where the download files are stored.

Enter the IP address of FTP/TFTP/HTTPS server with digit keys. Use Asterisk key for separator of IP address.

To enter the address (URI) of FTP/TFTP/HTTPS, press the **IP/URI** softkey to switch the display to the URI input screen.

Press the **IP/URI** softkey.

Use the dial keys to enter the address (URI) of the server where the files are stored.



Refer to [Appendix B Input Characters](#) for entering instructions for entering characters.

After entering address (URI), press or enter the **OK** softkey.



*The IP address input screen can be switched to a URI input screen using the **IP/URI** softkey.*

*Press the **IP/URI** softkey.*

*Press the **IP/URI** again to go back to the IP address input screen.*

- (14) Select **1** (Download Files).

(15) Select a file to be downloaded.

According to the selected item in the [Download Files], proceed to the following steps below.

Select 1 (Hold Music) and go to step 17.

File Format	Maximum Size
PCM μ -law wav.	under 32 seconds

Select 2 (Ring Tone) and go to step 16.

File Format	Maximum Size
PCM μ -law wav.	under 32 seconds
Linear PCM 16kHz wav.	under 32 seconds

Note: *ITK-8TCGX-2* and ITK-8LCX-2* do not support PCM μ -law wav.*

Select 3 (Directory) and go to step 17.

Select 4 (Wallpaper) and go to step 17.

(Wallpaper is only available in Classic mode.)

(16) Select between Music Ring 1~3.

(17) Enter the file name using the digit keys.

The default file name is displayed.

*Press the **BK** softkey once to delete the default file name.*

Enter the file name that is downloaded.



Refer to [Appendix B Input Characters](#) for entering instructions for entering characters.



Up to 64 characters can be entered as a file name.

(18) Press the **Exec** softkey.

The download starts.

(19) Press the **Exit** softkey.

The download starts.



When the download process ends in failure, "Downloading Failed!" is displayed on the LCD. Check to see the following points and retry download



*If you retry uploading multiple times and it continues to fail, the terminal may be in failure.
For details, contact the system administrator.*

Backing Up or Restoring the Terminal Setting Data

This section explains how to make a backup of the setting data, which has been entered in the terminal to FTP/TFTP/HTTPS server. The data in FTP/TFTP/HTTPS server can be also restored to the terminal.



*When downloading these files, the terminal needs to be connected to a network that has a FTP, TFTP or HTTPS server.
For details regarding the DTP/TFTP or HTTPS service, contact your system administrator.*

Back Up the Terminal Setting Data

- (1) Display the Menu screen, and select **Settings**.
- (2) Select **3** (Data Backup/Restore).
- (3) Select **4** (Protocol).
- (4) Select a Protocol type of the server where the backup file is stored.
- (5) According to the selection in [Protocol] screen,

proceed to the following steps below.

- (6) Display the Menu screen, and select **Settings**.

When 1 (FTP) is selected here, go to step 7.

When 2 (TFTP) is selected here, go to step 12.

When 3 (HTTPS) is selected here, go to 7.

- (7) Select **5** (Account Settings).

- (8) Select **1** (User ID).

- (9) Enter a User ID with digit keys.



Refer to [Appendix B Input Characters](#) for entering instructions for entering characters.

- (10) Select **2** (Password).

- (11) Enter a password with the digit keys.



Refer to [Appendix B Input Characters](#) for entering instructions for entering characters.

- (12) Select **3** (Folder).



Refer to [Appendix B Input Characters](#) for entering instructions for entering characters.

- (13) Enter the folder name where the download file is stored.



Refer to [Appendix B Input Characters](#) for entering instructions for entering characters.

Enter the name of the folder where the files are stored in the server (including the path from root directory to the folder where the backup file is stored).

- (14) Press the Left key or the **Back** softkey

- (15) Select **3** (Server Address).

- (16) Enter the IP address of FTP/TFTP/HTTPS server using the digit keys.

Use Asterisk key for separator of IP address.

To enter the address (URI) of FTP/TFTP/HTTPS, press Soft key (IP/URI) to switch the display to the URI input screen.

*Press the **IP/URI** softkey.*

Using the Dial keys, enter the address (URI) of the server where the files are stored.



Refer to [Appendix B Input Characters](#) for entering instructions for entering characters.



*The IP address input screen can be switched to a URI input screen using the **IP/URI** softkey.*

*Press the **IP/URI** softkey.*

*Press the **IP/URI** again to go back to the IP address input screen.*

- (17) Select **1** (Data Backup).

- (18) Enter the file name using the digit keys/

The default name is displayed.

*Press the **BK** softkey once to delete the default file name.*

Enter the file name that for the backup file.



Refer to [Appendix B Input Characters](#) for entering instructions for entering characters.



Up to 64 characters can be entered as a file name.



When you send the data from the terminal to the server, you can select the file format with encryption.

Press the **Enc** softkey to send the file with encryption.

Press the **No Enc** softkey to send the file without encryption.



Do not change the extension of the backup file. The setting data of the terminal can only be backed up as a (.tgz) / (.tgz.ef) file.

(19) Press the **Exec** softkey.

The backup starts.

(20) Press the **Exit** softkey.

The display goes back to the [Backup/Restore] screen.



When the backup process ends in failure, “Upload Failed!” is displayed on the LCD. Check to see the following points and retry backup.



If you retry uploading many times and it continues to fail, the terminal may be in failure.

For details, contact the system administrator.



If the upload fails for reasons other than the ones listed above, “Download Failed!” or “Upload Failed!” displays

Contact your system administrator.

Restore the Terminal Setting Data

- (1) Display the Menu screen and select **Settings**.
- (2) Select **3** (Data Backup/Restore).
- (3) Select **4** (Protocol).
- (4) Select a Protocol type of the server where the backup file is stored.
- (5) According to the selection in the [Protocol] screen, proceed according to the following steps.

When **1** (FTP) is selected here, go to 7.

When **2** (TFTP) is selected here, go to **11**.

When **3** (HTTPS) is selected here, go to 7.

- (6) Select **5** (Account Settings).
- (7) Select **1** (User ID).
- (8) Enter a **User ID** using the digit keys.



Refer to [Appendix B Input Characters](#) for entering instructions for entering characters.

- (9) Select **2** (Password).

(10) Enter a password using the digit keys.



Refer to [Appendix B Input Characters](#) for entering instructions for entering characters.

(11) Select **3** (Folder).

(12) Enter the folder name where the backup file is stored.



Refer to [Appendix B Input Characters](#) for entering instructions for entering characters.

Enter the name of the folder where the files are stored on the server (including the path from root directory to the folder where the backup file is stored).

(13) Press the Left key or the **Back** softkey.

(14) Select **3** (Server Address).

(15) Enter the IP address of FTP/TFTP/HTTPS server using the digit keys.

Use Asterisk key for separator of IP address.

To enter the address (URI) of FTP/TFTP/HTTPS, press the **IP/URI** softkey to switch the display to the URI input screen.

*Press the **IP/URI** softkey.*

By using the Dial keys, enter the address (URI) of the server where the files are stored.



Refer to [Appendix B Input Characters](#) for entering instructions for entering characters.



*The IP address input screen can be switched to a URI input screen using the **IP/URI** softkey.*

*Press the **IP/URI** softkey.*

*Press the **IP/URI** again to go back to the IP address input screen.*

(16) Select **2** (Data Restore).

(17) Enter the file name using the digit keys/

The default name is displayed.

*Press the **BK** softkey once to delete the default file name.*

Enter the file name that backed up in the [Backing Up or Restoring the Terminal Setting Data on page 36](#).



Refer to [Appendix B Input Characters](#) for entering instructions for entering characters.



Up to 64 characters can be entered as a file name.



When you send the data from the terminal to the server, you can select the file format with encryption.

*Press the **Enc** softkey to send the file with encryption.*

*Press the **No Enc** softkey to send the file without encryption.*



Do not change the extension of the backup file. The setting data of the terminal can only be backed up as a (.tgz) / (.tgz.ef) file.

(18) Press the **Exec** softkey.

The download starts.

(19) Press the **Exit** softkey.

The display goes back to the [Backup/Restore] screen.



When the backup process ends in failure, "Upload Failed!" is displayed on the LCD. Check to see the following points and retry backup.



If you retry uploading many times and it continues to fail, the terminal may be in failure. For details, contact the system administrator.



If the upload fails for reasons other than the ones listed above, "Download Failed!" or "Upload Failed!" displays. Contact your system administrator.

Making/Answering Calls with a Headset

By Using An Optional Headset, It Is Possible To Originate Or Respond To Calls.

When Using A Headset, The On-hook/off-hook Operation Can Be Made Using Headset/handset Feature Key.



The feature key is set with system data setting at initial installation. For details, contact your system administrator.

Make a Call Using a Headset

While placing the handset on the terminal, make a call using the headset.

- (1) Press The **Headset/handset** Feature Key.
Headset/handset Feature Key Lamp Lights Red.
Line Key Lamp Lights Green.
- (2) Dial A Desired Number.
- (3) Start A Conversation After The Called Party Answers.
- (4) Press The **Headset/handset** Feature Key Once Again, After Finishing A Call.
The Headset/Handset Feature Key lamp goes off.
The line key lamp light goes off.

Answer a Call Using a Headset

While placing the handset on the terminal, answer a call using the headset.

- (1) While hearing a ringing tone, press the **Headset/Handset** feature key.
Feature key lamp lights red.
- (2) Start conversation with the calling party.
- (3) Press the **Headset/Handset** feature key once again, after finishing a call.
The Headset/Handset feature key lamp goes off.

The line key lamp light goes off.



*During a call in progress using the handset, you can switch to the headset by pressing the **Headset/Handset** feature key.*

*It is possible to answer a call by pressing line key after pressing the **Headset/Handset** feature key. You can also answer a call by pressing the **Answer** key after pressing the **Headset/Handset** feature key.*

For details, contact your system administrator.

Setting a Bluetooth Device



A Bluetooth device is available for DT930 (Touch panel model).



Please contact a dealer about recommended Bluetooth devices. If you use devices that are not recommended, you might not be able to connect the device or talk.

You must first pair the desired Bluetooth device to the telephone.

Enable the Bluetooth Function

- (1) Display the Menu screen and select **Settings**.
- (2) Select **1** (User Settings).
- (3) Select **6** (Option Device).
- (4) Select **1** (Bluetooth).
- (5) Select **1** (Bluetooth Mode).
- (6) Select **2** (Enable).

Pair and Connect the Bluetooth

- (1) Display the Menu screen and select **Settings**.
- (2) Select **1** (User Settings).
- (3) Select **6** (Option Device).
- (4) Select **1** (Bluetooth).
- (5) Select **2** (Pairing).
- (6) Select **1** (Inquiry).

While Inquiry, display as follows.

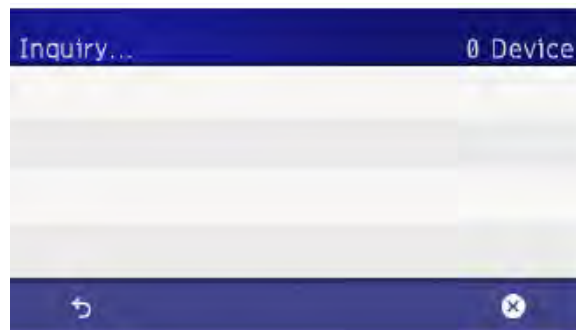

- (7) Select device to pair.

Display example of inquiry list.

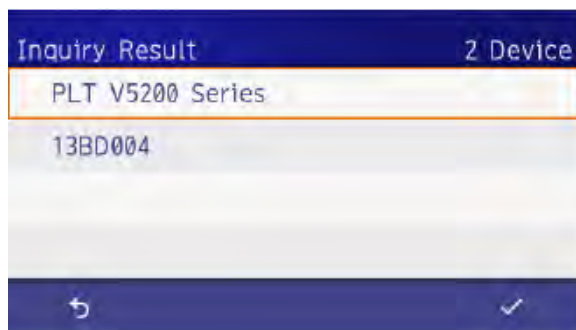

Display example of dedicated device names.

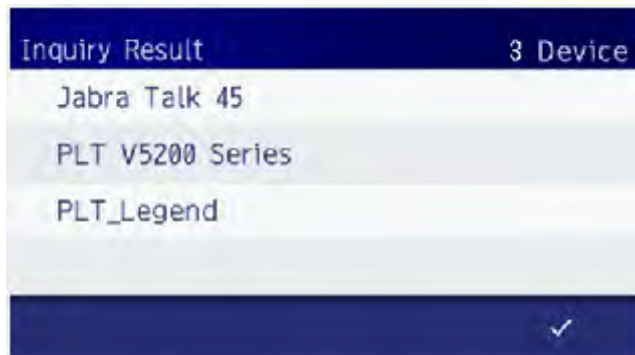

You can only pair one device.



When you select the paired device, it connects to the telephone automatically.





When connecting a Bluetooth device, use it within a distance of 30 meters (32.8 yards) from the phone.



Up to 16 Bluetooth devices can be installed on the same floor within 10 meters (10.9 yards).

You can check the connecting status of Bluetooth device with following status icons.

Icon	Description
 Bluetooth Connecting	Indicates the Bluetooth device and the telephone are connecting.
 Bluetooth not Connected	Indicates the Bluetooth device and the telephone are not connected.
 Bluetooth Error	Indicates there is an error in the Bluetooth module in the telephone. Contact the system administrator.



If there is a temporary disconnection between telephone and Bluetooth device, which occurred when Bluetooth mode switches off, the Bluetooth device reconnects to the telephone when telephone switches on or Bluetooth mode is turned on.



Example using Voyager5200:

You can reconnect by pressing the talk button. To verify that the device is connected check the pairing list.



When the Bluetooth connection between the Jabra Speak 810 and the terminal is lost, Jabra Speak 810 does not automatically reconnect to the paired terminal. When this occurs, pair it again using the User Settings.

Check the Pairing Device And Disconnect

- (1) Display the Menu screen and select **Settings**.
- (2) Select **1** (User Settings).
- (3) Select **6** (Option Device).
- (4) Select **1** (Bluetooth).
- (5) Select **2** (Pairing).
- (6) Select **2** (Pairing List).
- (7) Check the connecting device.
“  ” Indication is displayed with the connecting device. If the device is not connected, “  ” is not displayed.

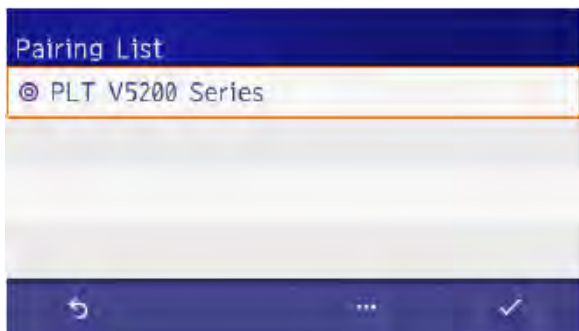

- (8) If you want to disconnect the device, press **3** (Option) local softkey.

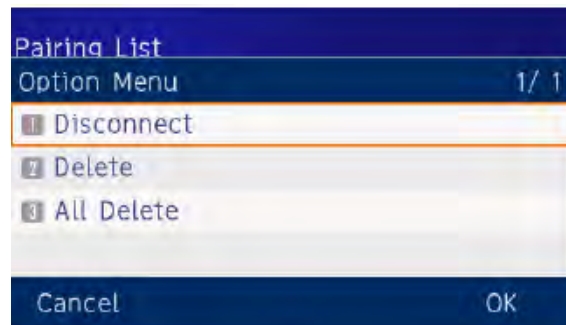

- (9) Select **1** (Disconnect).



You can switch connect and disconnect device easily by tapping the device name at procedure 4 Is this referring to step 4 'Select 1 (Bluetooth)'.

Change Inquiry Time

- (1) Display the Menu screen and select **Settings**.
- (2) Select **1** (User Settings).
- (3) Select **6** (Option Device).
- (4) Select **1** (Bluetooth).
- (5) Select **3** (Additional setting).
- (6) Select **1** (Inquiry Time).
- (7) Select desired inquiry time.

Display Bluetooth Module Information

- (1) Display the Menu screen and select **Settings**.
- (2) Select **1** (User Settings).
- (3) Select **6** (Option Device).
- (4) Select **1** (Bluetooth).

- (5) Select **4** (Bluetooth Information).
- (6) Displayed information as follows.

Device name
Device address
Firmware version
Core version
Profile Name

Multi-Window Service

Multiple XML applications can be displayed at the same time. A maximum of four applications can be run simultaneously, including Phone Screen and other applications that are registered in the Home URL.

Switching XML Applications

You can use Menu screen to switch windows to display the application.



If the XM: application is not set, the most recently used XML application (i.e., Favorite, Phonebook, Terminal Settings) that the phone has by default is displayed.
When the phonebook is displayed, the title of the phonebook is also displayed.

- (1) Press the **Menu** key to display the Menu screen.
- (2) Select the application from the **Menu** screen that you want to launch.



It is possible to display each of the XML applications.



The following XML application screen is an example.

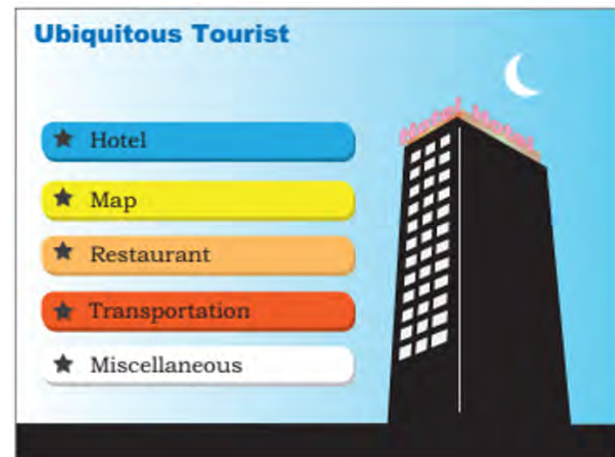

Existing XML Applications

- (1) Press the **Home** key while displaying the XML application on the screen.



After the XML application closes, the other applications that are launching are displayed in order that they opened, starting from the left.

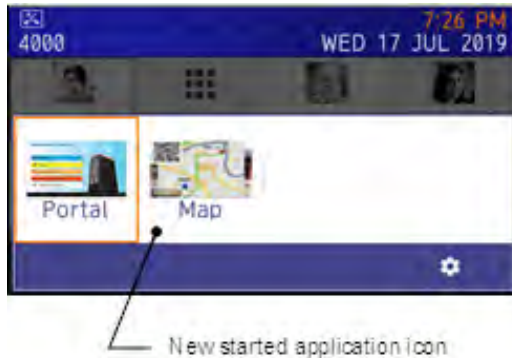

Launching the Fifth Application

You can launch up to four XML applications. If you try to launch a fifth application, an error message is displayed asking you to exit one of the currently running applications, which is displayed. While this error message is displayed, you cannot execute any operations on XML applications.

- (1) When you have four applications launched and you try to launch a fifth application, the following error message displays asking you to exit one of the currently running applications.

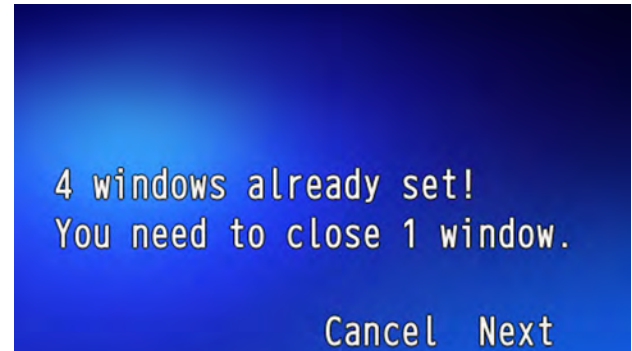

- (2) Press the **Next** softkey on the error message screen.

TIP

If you do not operate anything for 10 seconds after an error message is displayed, the launching of the new application is automatically canceled.

- (3) Select the application you want to close and press the **Trash** icon.

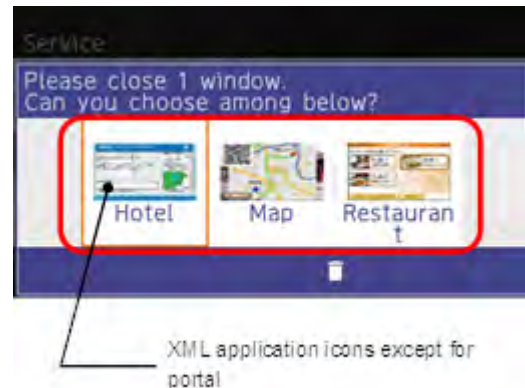

(4) You can now launch the new application.

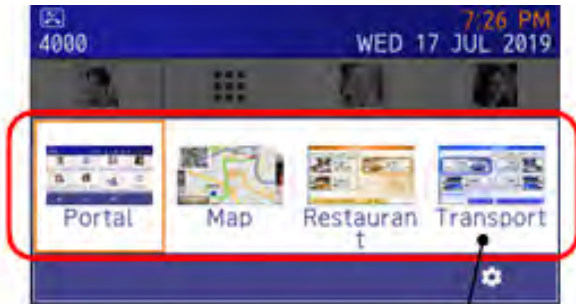

New started application icon

TIP The **NEW** and **UPDATE** icons flash every second.

The **NEW** icon is displayed when the application orders to display an icon that was formerly not displayed.

UPDATE icon is displayed when the window of the XML application is updated.

Icon Display at XML Application Update

The service icons displayed on the menu screen are reduced screen images of actual XML application screens. The icon and the actual application display may differ because the system cannot iconize the screen image until it actually displays the application windows.



NEW icon
UPDATE icon

- (1) NEW Icon
- (2) UPDATE Icon

3 Basic Operation

This chapter describes the basic operation of the DT930/DT920.



Press the **Home** key to return to the Favorite screen (Default). If the Home Screen is set to Call screen or Line screen, return to [Setting Home Screen on page 32](#).

Shortcut

On the Favorite screen, the shortcut icons that you registered are displayed. You can easily make a call using the registered number, which are typically numbers that you use often. The shortcut icons also allow you to quickly access service URLs.

There are four types of shortcuts. A maximum of eight items can be registered.

A contact person who is registered in the SV9100 Internal Extension List

A telephone number that is frequently dialed (a maximum of 16 digits).

The service menu button provided by an XML application such as a Redial button.

Redial button.



If the URL is not registered in the **configuration setting**, it cannot be used even if you register the service shortcut. For details, contact your system administrator.



There are three types of shortcut photo and name settings.

Small Photo and Name
Displays the photo registered in the contact in a small size, and displays the shortcut name below the photo .

Photo and Name
Displays the photo registered in the contact in a large size, and displays the shortcut name over the photo .

Photo Only
Displays the photo registered in the contact in a large size. Shortcut name is not displayed .

For the setting method, refer to [To Change Shortcut Display](#).

How to select system soft key

DT930 (Touch Panel model)
Tap the shortcut, Only when the item is selected, the orange focus is displayed until the screen changes to the next screen.

DT920 (Self Labeling model)
Press programmable key on the sides of the screen.



Favorite Screen

The following diagram shows every type of shortcut.

Contact Person: The picture is registered in the SV9100 Internal Extension List.

Telephone Number: The icon picture is chosen at the time the shortcut is registered.



Service



Service 1~4



Redial



Unregistered Shortcut



Shortcut Name

The following shows names that are displayed for every type shortcut.

Contact Person: The name is registered in the SV9100 Internal Extension List.

Telephone Number: The name is entered at the time the shortcut is registered.

Service: **Service** is displayed.

Service 1~4: The name selected during shortcut registration.

Unregistered Shortcut: No name is indicated.

A shortcut name is approximately 10 characters in length, depending on the character string. When the width exceeds the display area, the right end of the character string could be truncated.

Register a Shortcut

The following procedure explains how to register a shortcut. In this example, a telephone number is registered.

- (1) Select the unregistered shortcut you want to register with number you want to dial.

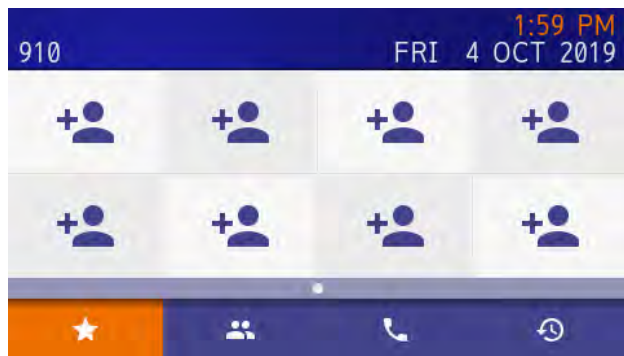

- (2) Select **2** (Dial).

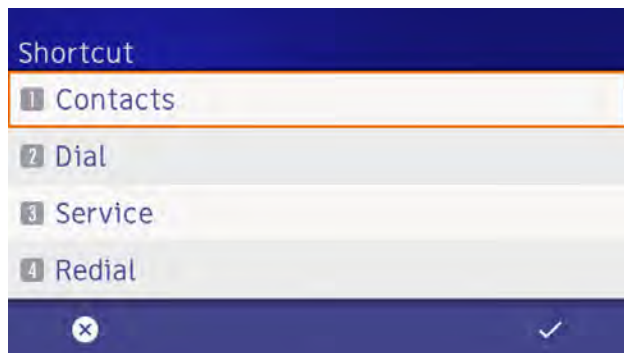

- (3) Enter the desired number.

The number is 1 to 16 characters in length.

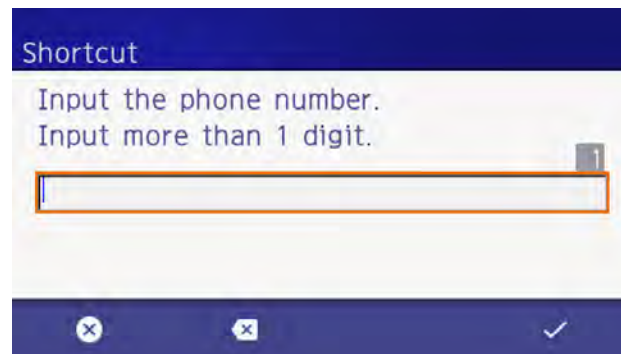

- (4) Enter the desired shortcut name.

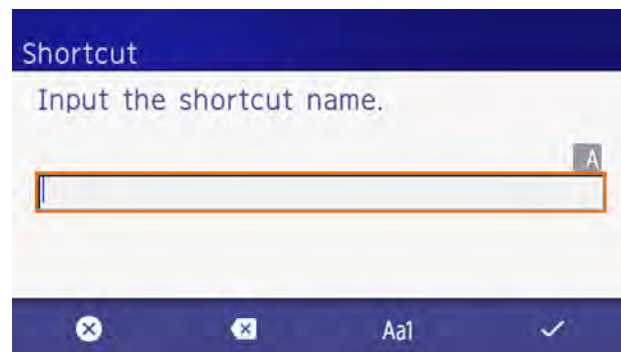

(5) Select the desired shortcut icon.

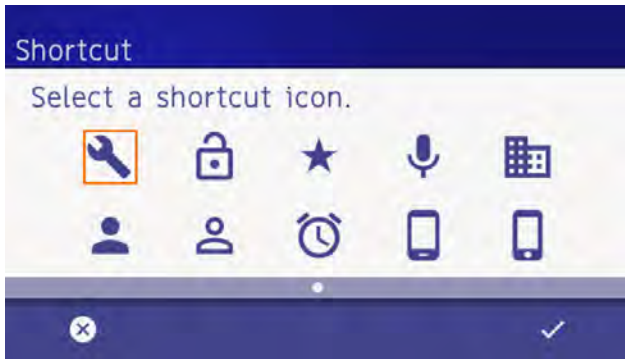

(6) The registered shortcut is displayed.



After a second, the input characters and selected icon are displayed.

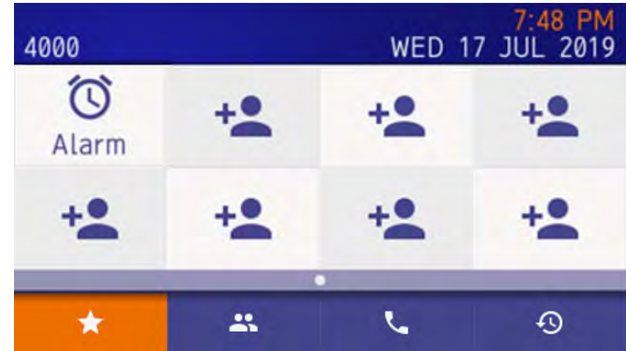

Use a Shortcut

This procedure explains how to use a shortcut.

In this example, a call is made to a contact person who has been registered in the SV9100 Internal Extension List.

(1) Select a registered shortcut.

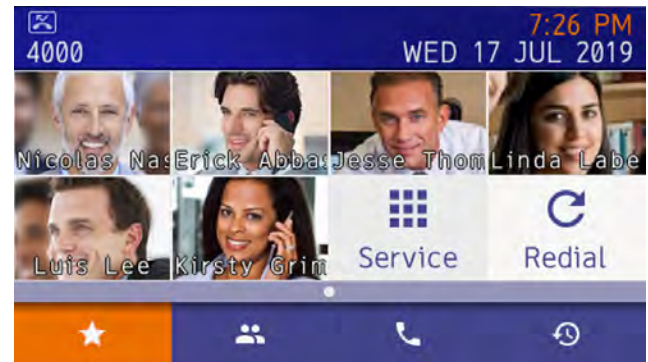

(2) The Profile screen is displayed.

You can call the person by pressing **3** (local softkey). You can also call by picking up the handset and pressing either the **Enter** or **Speaker** key.

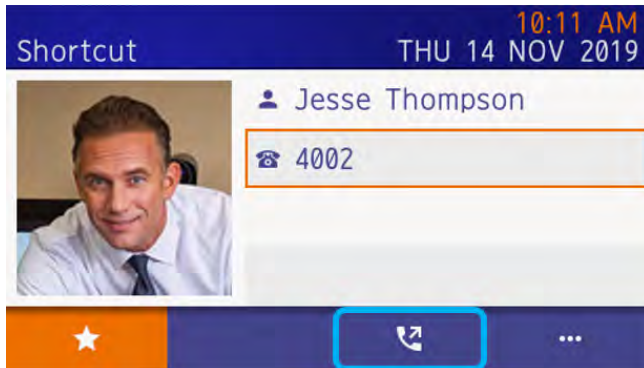

Ensure that the dialed number is focused before you make the call. If a number is not focused you cannot make the call.



To add and send a prefix, use the following procedure.

- (1) Press the 4 (Option) softkey on the Profile screen. 
- (2) Select the 1 (Prefix). Refer [Make Calls with a Prefix on page 57](#).

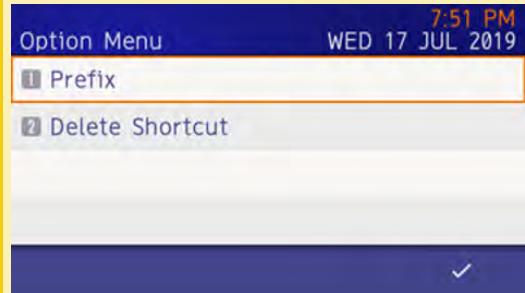

- (3) Select the prefix number you want to add and press **4** (local softkey). You can call a number with the prefix. It is also possible to call the number by picking up the handset and pressing either the **Enter** or **Speaker** key.

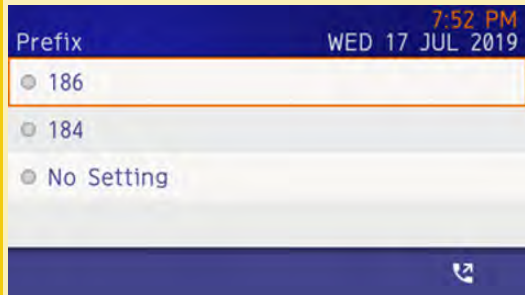

(3) The calling screen is displayed.

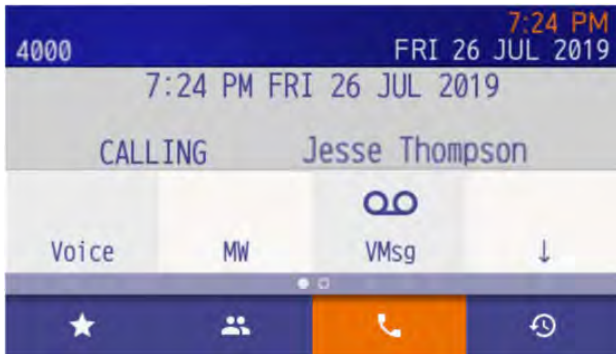

When you start talking with the called party, the following screen is displayed.

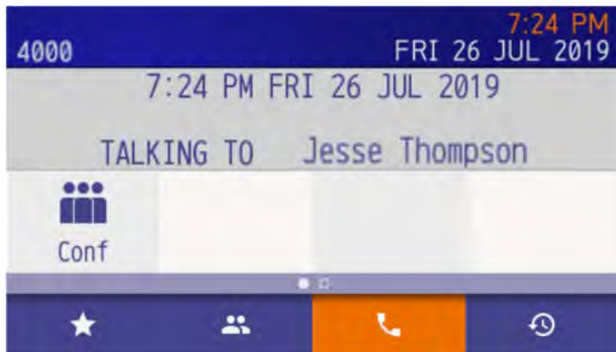

(4) End the call by returning the handset in the cradle or pressing the **Speaker** key.



To upload an image to a shortcut, refer to the Appendix [To Upload an Image](#).

Edit Shortcut



The shortcut types cannot be edited using this method. Only the shortcut information registered by entering can be edited.

To change the shortcut type, delete the shortcut and register again. For register or delete shortcut, refer to [Register a Shortcut on page 49](#) or [Delete a Shortcut on page 53](#).

The Redial shortcut cannot be edited.

(1) Select a registered shortcut.

Select a registered shortcut using a long press (long tap).



How to Select by Long Press:

DT930 (Touch panel model)

Long press the shortcut. Only when the item is selected, the orange focus is displayed until the screen transitions to the next screen.

DT920 (Self labeling model)

Long press the programmable key on the sides of screen.

(2) Select **Edit Shortcut**.

The option menu is displayed, select **Edit shortcut**.

(3) Select **Data**.

The Data select screen is displayed. Select the data to be edited.

(4) Edit the data.

Edit the registered information and press **Enter** or the local Soft key **4**.

- (5) The information is refreshed.

When editing is completed, the following screen is displayed. After a moment, the screen returns to the Favorite screen.

Delete a Shortcut

There are two ways to delete a shortcut. One way is from the Registered Favorite screen and the other way is from User Settings. You can delete some or all of the shortcuts from User Settings.

From a Registered Shortcut

This procedure explains how to individual delete a shortcut.

- (1) Select a registered shortcut (long press).
- (2) Select **2** (Delete Shortcut).
- (3) Confirm the deletion by pressing **Enter** or **4** (local soft key).

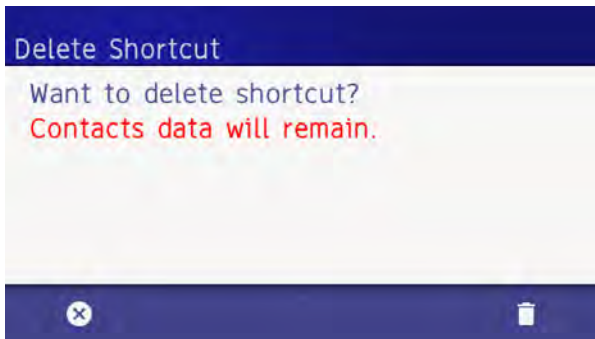

- (4) The shortcut is deleted from the Favorite screen. When the shortcut is successfully deleted, the following message is displayed.

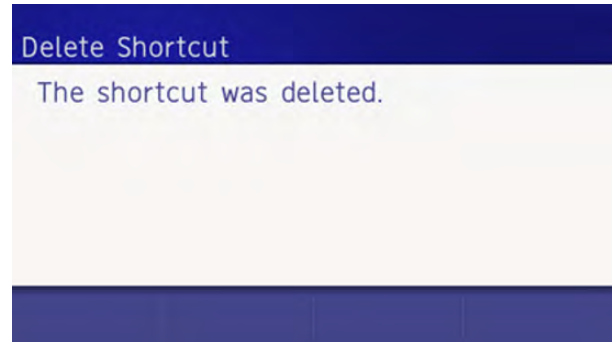

After a second, the Favorite screen is displayed.

From the User Setting

This procedure explains how to delete individual shortcuts or all shortcuts from the User Setting.

- (1) From the Menu screen, select **Settings**.

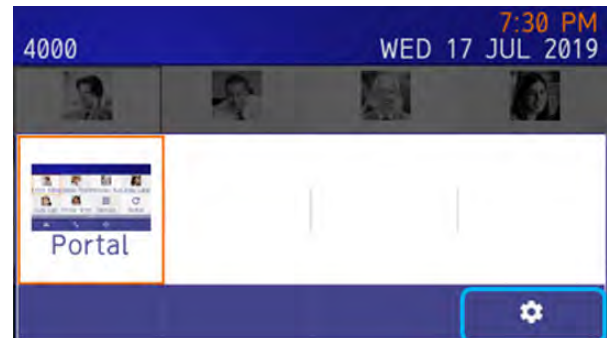

- (2) When the Delete Shortcut menu displays, select one of the following options.
 - Enter Menu Settings.
 - Select **1** (User Settings)
 - Select **3** (Display)
 - Select **7** (Portal Mode Setting)
 - Select **1** (Delete Shortcut)

Select the shortcut you want to delete.

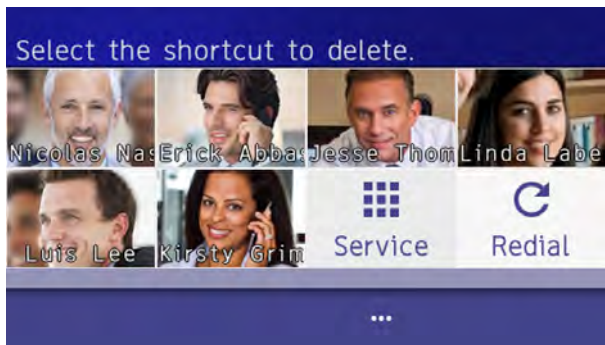

If you want to delete ALL shortcuts, follow the steps listed below.

- (1) Select the option with **softkey 3**.
- (2) Select **1** (Delete All)

Option Menu

1 Delete All

- (3) Confirm that you want delete ALL of the shortcuts.

If you want to cancel the deletion, press the **Back** key.

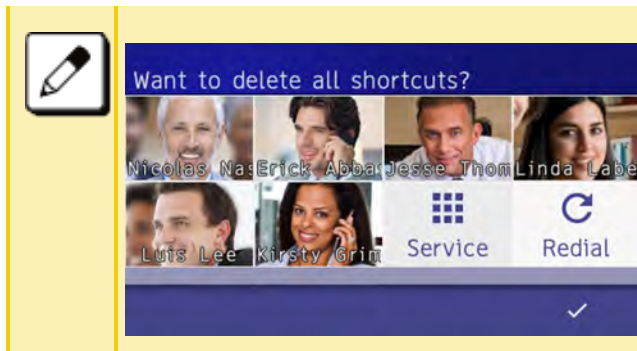

When the shortcut is successfully deleted, the following message is displayed.

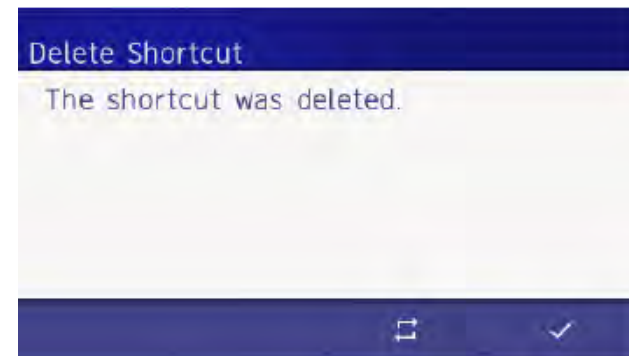

- (3) If you want to delete another shortcut, press **3** soft key.

To Change Shortcut Display

The following explains how to change the display for shortcuts on the Favorite screen.

- (1) Display the **Menu** screen, and select **Settings**.

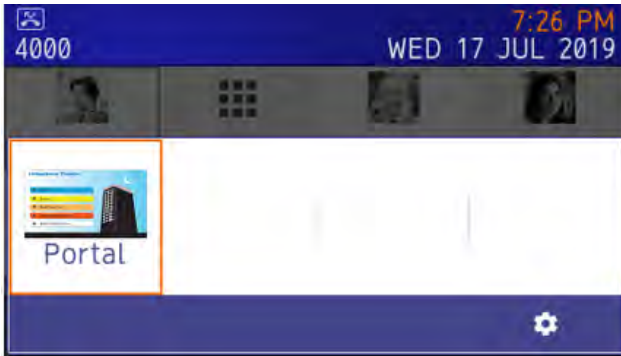

- (2) Display **Shortcut Photo & Name**.
- (3) Select **1** (User Settings).
- (4) Select **3** (Display).
- (5) Select **7** (Portal Mode Setting).
- (6) Select **5** (Shortcut Photo & Name).
- (7) Select a desired display method.



The default setting is 2, Photo & Name.

System

Use the System Softkey

To select the system softkey, tap the system soft key if you are using the DT930 touch panel telephone (ITK-8TCGX). If you are using the DT920 self labeling telephone (ITK-8LCX), you can select system soft key by pressing programmable key. The Up and Down cursor keys can be used to adjust the volume when you are using this screen.

The Left and Right cursor keys can be used to move to Line screen.

DT930 Touch Panel Model

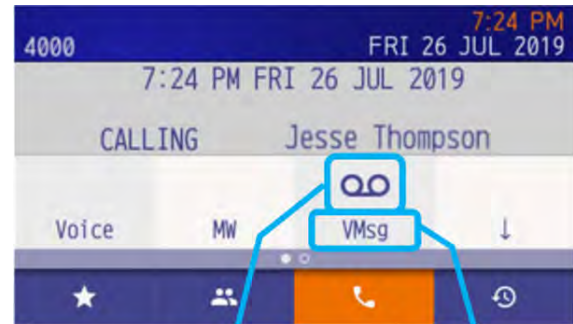

System soft key icon

System soft key name

DT930 Self Labeling Model

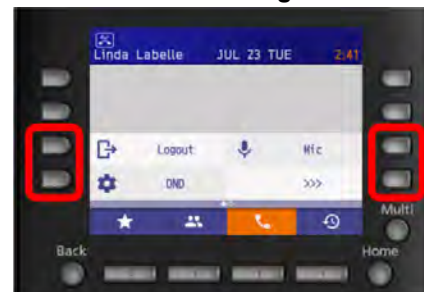



To display the next system softkey page, select >>>.

If there is not next page, >>> is not displayed.



The **Up** and **Down** cursor keys can be used to adjust the volume when you are using this screen.

These keys are not used for selecting the system softkey.

Phone Book

You can use the Personal Phone Book and the System Phone Book.



Whether you can use a Personal Phone Book depends on system data settings.

For details, contact the system administrator

Personal Phone Book



To perform phone operations other than making calls from the phonebook, switch to the Call screen. The Hold button cannot be used on the personal phonebook screen.



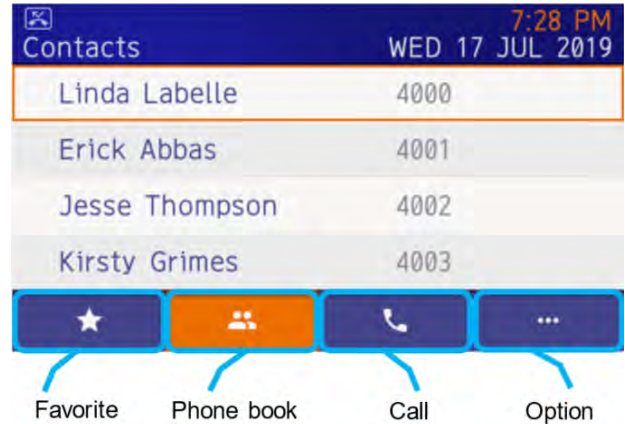



- (1) Press the local softkey **2** (Phone Book) on the Favorite screen or Call screen.

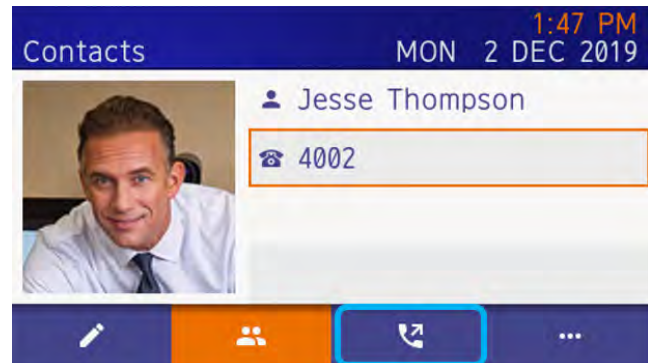





Search for a Person

- (1) Press the local softkey **4** (Option).
- (2) From the Option menu, select **1** (Search).
- (3) Enter the search name.
- (4) Select the person from the candidate list.



Icon	Data Name	Explanation
	The Name	The name of the partner is indicated.
	The Japanese Syllabary	The Japanese syllabary of the name of the partner is indicated.
	Company Name	The company name to which a partner belongs is indicated.
	Telephone Number 1~4	Four telephone numbers can be registered. When a category is designated, an icon of a category is indicated.
	Group	The registered group name is indicated.
	Ringtone	The ringtone color when an arrival was here from the registered telephone number (the name), is indicated.
	Illuminations	The flash color of the arrival lamp when an arrival was here from the registered telephone number (the name), is indicated.

The category indicated by the telephone number item is as follows.

Category	Icon
Company	
Cell Phone	
Voice Mail	
Home	
Others	

Make Calls using the Phone Book

You can call using Phone Book without pushing dial button.

From Candidate List

- (1) Search for a person and display candidate list. Refer to [Search for a Person on page 56](#).
- (2) Select the person you want to call and make the call.

From Shortcut Detail

- (1) Search for a person and display candidate list. Refer to [Search for a Person on page 56](#).
- (2) Select the number you want to call and make the call.

Make Calls with a Prefix

- (1) Search for a person and display candidate list. Refer to [Search for a Person on page 56](#).
- (2) Select the person you want to call and press local softkey **4** (Option).
- (3) Select **1** (Prefix).
- (4) Select the desired prefix number and make the call.

Delete Messages

- (1) Search for a person and display candidate list. Refer to [Search for a Person on page 56](#).
- (2) Press local softkey **4** (Option) with focused data.
- (3) Select **5** (Delete).
- (4) Press local softkey **4** (OK) on the confirmation window.

- (5) Delete message is displayed.

History

Start History

- (1) Press **List**.
- (2) Press **Redial** or **CID** to display an item from history.

Display History Data

- (1) Press **List**.
- (2) Press **Redial** or **CID** to display an item from history.
- (3) Detailed information of the last call is displayed.

Make a Call

- (1) Press **List**.
- (2) Press **Redial** or **CID** to display an item from history.
- (3) Detailed information of the last call is displayed.
- (4) Lift the Handset or press **Speaker** to dial the displayed number.

Register

- (1) Display the Call History data of the target telephone number (refer to [Make a Call](#)).
- (2) Press **Store**.
- (3) Select **STA** to store the number in a Speed Dial bin or select **SPD** to the number store in a System Speed Dial bin. Select **TELBK** to store the number in a Telephone Book.

Delete

- (1) Display the Call History data of the target telephone number (refer to [Make a Call](#)).
- (2) Press **DEL**.
- (3) Select **One** to delete a single call or **All** to delete all call histories.

4 Feature Operation

This chapter describes how to login/logout, how to input characters and make a call, put a call on hold, etc.

Login

When login mode is activated, the telephone prompts for Login ID and Password. When the telephone starts, Login Mode is activated.

- (1) Enter Login ID and press the **Set** softkey.



At initial setting, enter the extension number as the Login ID.



A maximum of 16 characters can be entered for the Login ID.

- (2) Enter a password and press the **OK** softkey.
- (3) If the Login ID and password is accepted, the display changes to normal idle status. The telephone is logged in.



*If you enter an incorrect Login ID and Password, the normal screen is not displayed; the display returns to the Login screen.
Enter the correct Login ID and Password.*

Logoff

The terminal, which is operated with Login Mode, can log out. The following is an example for the ITK-8TCGX terminal. If using the ITK-8LCX terminal, apply the programmable key.

- (1) When login Press system softkey ↓ .

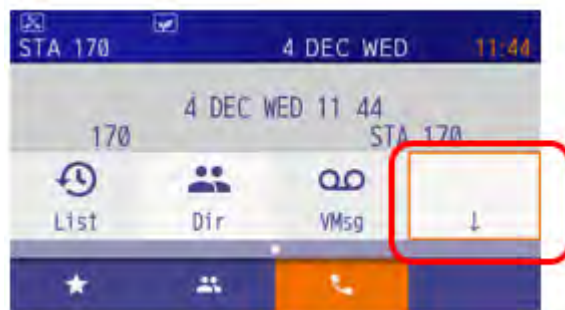

- (2) Press system softkey **Prog**.

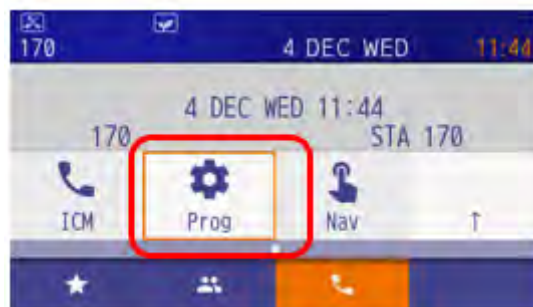

- (3) Press system softkey ↓ three times.

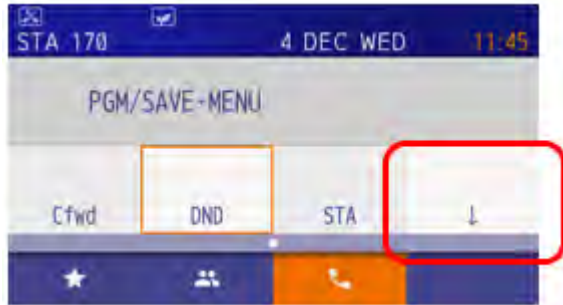

- (4) Press system softkey **LOGOFF**.

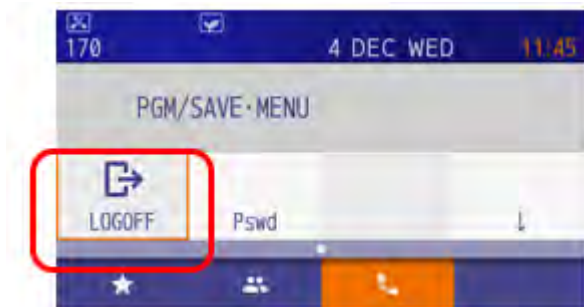

- (5) Press system softkey **Yes**.

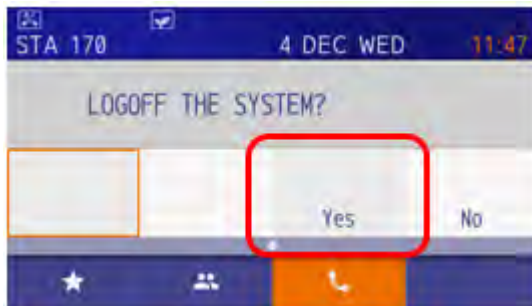

The terminal logs off.

Making Calls

This section explains Preset Dialing. Before making a call, the you can verify the dialed number, which is displayed on the LCD. When an incorrect number is entered, you can correct the number before originating the call.

Make an External Call

This procedure explains how to originate an external call using the Speaker key.

- (1) After dialing the Central Office access code, dial the number you want to call.
- (2) Press the **Speaker** key.

The Speaker key lamp lights red.

Make an Internal Call

This procedure explains how to originate an internal call using the Speaker key

- (1) Dial the number you want to call.
- (2) Press the **Speaker** key.

The Speaker key lamp lights red.

Answering Calls

This section explains how to answer calls using the Answer key.

Answer an External Call

- (1) The Answer key and Line key lamps flash red (the ITK-8TCGX telephone Line key flashes green).
- (2) Press the **Answer** key.
The Call Indicator lamp goes off.
The Answer key lamp goes off.
The Speaker key lamp lights red.
The Line key lamp lights green.
- (3) Lift the handset to answer the call.



It is possible to answer a call by pressing the Line key that is flashing instead of using the Answer key.



It is possible to answer a call by lifting the handset, then pressing the Answer key or Line key.

Answer an Internal Call

The following procedure explains how to answer an internal call routed to the telephone.

- (1) When you hear the ringing tone, the Call Indicator lamp flashes red, the Answer key and Line key lamps light green.
- (2) Press the **Answer** key.
The Call Indicator lamp goes off.
The Answer key lamp goes off.
The Speaker key lamp lights red.

- (3) Lift the handset to answer the call.

Holding a Call (using Call Hold)

You can use this feature to put a call, which is in progress, on hold using the call Hold key. The line can then be used to originate another call or return to the previously held call.

Put a Call on Hold

This procedure explains how to put a call, which is in progress, on hold.

- (1) While a call is in progress, the Line key that is used during the call lights green. The Line key on other telephones lights red.
- (2) Press the **Hold** key.
The caller on hold hears Music on Hold.
The Line key, which is on hold, flashes green.
The Line key on other telephones flashes red.
- (3) Replace the handset or make a new call.

Retrieve the Call on Hold

This procedure explains how to retrieve a call that was previously put on hold.

- (1) While the call is holding, the Line key that is used to place the caller on hold flashes green.
- (2) Press the **Line** key that is on holding.
The Line key lamp lights green.
- (3) Lift the handset and return to the call on hold.



It is possible to retrieve the call on hold from another telephone that has the same Line key flashing red.



If the call goes unanswered after a predetermined time, Automatic Recall is initiated. The user hears an Automatic Recall ringer tone. The default time frame is 90 seconds.



*The time frame for the Automatic Recall ringer tone is assigned in system data settings during initial installation.
For details, contact the system administrator.*

Holding a Call (using Exclusive Call Hold)

You can use this feature to put a call on Hold and exclude all other telephone users from retrieving the held call.

Put a Call on Exclusive Call Hold

This procedure explains how to put a call, which is in progress, on exclusive call hold.

- (1) While a call is in progress, the Line key that is used during the call lights green. The Line key on other telephones lights red.
- (2) Press the **Feature** key.
The Feature key lamp lights red.
- (3) Press the **Hold** key.
The Line key, which is on hold, flashes green.
The Line key on other telephones light red (the ITK-8TCGX telephone lights green).
The Feature key lamp goes off.
- (4) Replace the handset.

Retrieve the Exclusive Call on Hold

This procedure explains how to retrieve a call that was previously put on exclusive call hold.

- (1) While the call is holding, the Line key that is used to place the caller on hold flashes green.
- (2) Press the **Line** key that is on hold.
The Line key lamp that was placed on hold lights green.
The Line key on other telephones lights red.
- (3) Lift the handset and return to the held call.



Only the terminal where Exclusive Hold is set can retrieve the call.



If the call goes unanswered after a predetermined time, Automatic Recall is initiated. The user hears an Automatic Recall ringer tone. The default time frame is 90 seconds.



*The time frame for the Automatic Recall ringer tone is assigned in system data settings during initial installation.
For details, contact the system administrator.*

Transfer a Call

This section explains how to transfer calls to another telephone within the system. It also explains how to answer the transferred calls.

Transfer a Call with Announcement

This procedure explains how to transfer a call when you want to announce the transfer to the called party.

Initiate a Transfer using Extension 200

- (1) With the call in progress, the Line key lamp lights green.
- (2) Press the **Transfer** key.
A special dial tone is heard.
The calling party is placed on hold.
- (3) Dial the destination extension number.
- (4) When the destination extension call is answered, announce to the user who answered the call that a call is being transferred.
- (5) Replace the handset.
The Line key lamp lights red.
The call is transferred.

Transfer a Call without an Announcement

This procedure explains how to transfer a call when you do not want to announce transfer to the called party. After entering the transfer destination number, simply return the handset to the cradle before the transferred call is answered. When the called is answered at the transfer destination, the parties are automatically connected. The phone number for the transferred party is displayed LCD on the destination telephone.

Initiate a Transfer using Extension 200

- (1) With the call in progress, the Line key lamp lights green.
- (2) Press the **Transfer** key.
A special dial tone is heard.
The calling party is placed on hold.
- (3) Dial the destination extension number.
- (4) Replace the handset.
The Line key lamp flashes red.
The call is transferred.

Answer a Transferred Call using Extension 210

This procedure describes how to answer a call that has been transferred.

- (1) When the telephone rings, the following occurs:
The Call Indicator lamp flashes.
The Line key lamp flashes red.
The extension number, where the call was initiated, displays on the telephone LCD.
- (2) Lift the handset to start a conversation with the transferred party.
The Call Indicator lamp goes off.
- (3) Extension user 200 goes on-hook to complete the transfer.



When the destination party does not answer within the predetermined time frame, the system recalls the telephone that initiated the transfer.

When the recall is retrieved, the destination number is displayed on the LCD.

Last Number Redial

You can search and redial previously dialed phone numbers. You can dial up to the last 50 previously dialed calls.

- (1) Press **LIST**.
- (2) Press **Redial**.
- (3) Press **↑** and **↓** or press the **Up** and **Down** key to find the number you want to dial.
- (4) Enter **#**.

The number displayed on the telephone LCD is automatically redialed.

- (5) When the phone answers, lift the handset.

One-Touch Speed Calling Keys

This feature allows you to dial frequently called numbers by pressing a One-Touch key, which has been assigned for Station Speed Dialing.

- (1) Press **01** (One-Touch Speed Dial Calling).
The Speaker key lamp lights red.
- (2) The number is automatically dialed.



Up to 32 digits can be registered for each dial number.



*The Feature key is assigned in system data settings during initial installation.
For details, contact the system administrator.*

Program One-Touch Speed Dial Calling Key

This procedure explains how to register a phone number to a One-Touch Speed Calling key.

- (1) Press the **Speaker** key.
- (2) Enter **751**.
- (3) Enter **01** (One-Touch Speed Dial Calling).
- (4) Enter the number you want to register.
- (5) Press the **Hold** key.



If you dial a wrong number, you will need to start from the beginning.



*To register a pause, press between any digits.
The pause can not be registered as a first digit.*



When a phone number is already registered as a One-touch key, that number is displayed on the LCD.

The previous number is cleared when you register a new number.

Verify One-Touch Speed Dial Calling Key

This procedure explains how to confirm the registered number in the One-touch Speed Calling key.

- (1) Press the **Right** and **Left** keys to display One-Touch Speed Dial Calling (**01**) on the page.
The Feature key lamp lights red.

- (2) Press a desired **One-touch Speed Calling** key.
The Feature key lamp flashes red.
The Speaker key lamp lights red.
- (3) Press the **Speaker** key.
The Feature key lamp goes off.
The Speaker key lamp goes off.

Station Speed Dialing

This feature allows a terminal user to dial long-digit or frequently-called numbers by pressing a Feature key and abbreviated code.

Register for Station Speed Dialing



*The feature is set to the terminal by system data setting at initial installation.
For details, contact the system administrator.*

- (1) Press the **Speaker** key.
- (2) Enter the **Station Speed Dialing code**.
- (3) Enter the **Speed Dial** you want to register (e.g., 001).
- (4) Enter the **call number**.
- (5) Press the **Hold** key.
- (6) Enter the **caller name**.
- (7) Press the **Hold** key.
- (8) Press the **Speaker** key.

Make a Call Using Station Speed Dialing

- (1) Press **Dir**.
- (2) Press **ABB**.
- (3) Search for the name you want to call or press \uparrow and \downarrow to select the name.
- (4) Press **Dial** or **Speaker**.

Originating a Voice Call

Instead of ringing, this feature informs the incoming call by voice.



*This feature is set using a Softkey or Feature key. The Feature key is set by system data setting at initial installation.
For details, contact the system administrator.*

- (1) Press the **Speaker** key.
You will receive a dial tone.
Speaker key lamp lights red.
- (2) Dial extension number.
You will receive a ring back tone.
- (3) Press **Voice** or enter **1**.
- (4) Lift the handset and announce an incoming call by voice to called party.
Speaker key lamp goes off.
- (5) Start conversation after called party answered.



***VOICE** is displayed on the called party's LCD.*

Three/Four-Party Conference

This feature provides a terminal user the ability to add another party to a call already in progress.



This feature is set using a Softkey or Feature key. The Feature key is set by system data setting at initial installation.

For details, contact the system administrator.

- (1) The party at extension A (200) and the party at extension B (201) are engaged in a 2-party connection.
They want to add the party at extension C to the conversation.
- (2) The party at extension A presses the **Conf**.
The party at extension A receives a special dial tone.
The party at extension B receives Music on Hold.
- (3) The party at extension A dials the number of extension C (210).
- (4) The party at extension C answers.
- (5) The party at extension A presses **Add**
- (6) The party at extension A presses **Begin**.

Voice Mail

This procedure explains how to access to the Voice Mail System.

Portal Mode

- (1) Press softkey **2**.
- (2) Use the cursor to tab to the right to access VMsg.
- (3) Press **VMsg**.

Classic Mode

- (1) Press softkey **3**.



For details of Voice Mail operations, refer to the Voice Mail System documentation.

Preset Answer

It is possible to respond by simply lifting the telephone handset.

Set Preset Answer

- (1) The **Answer** key lamp goes off.
- (2) Press the **Feature** key.
The Feature key lamp lights red.
- (3) Press the **Answer** key.
Feature key lamp goes off.
Answer key lamp lights red.

Answer to a Call With Preset Answer

- (1) The Ringing and the Call Indicator lamps flash.
- (2) Lift the handset.
The Call Indicator Lamp goes off.

Cancel Preset Answer

- (1) While Answer key lamp lights red, press the **Feature** key.
Feature key lamp lights red.
- (2) Press the **Answer** key.
The Feature key lamp goes off.
The Answer key lamp goes off.

Switching Voice from Handset to Speaker (Listen-Only)

You can change the telephone to “listen-only” during the call in progress. You can hear the caller's voice from the speaker on the telephone when you place the handset on-hook.

Hear Caller's Voice from the Speaker

- (1) With a call in progress, press the **Speaker** key.
The Speaker key lamp lights red.
- (2) Replace the handset.
You can now hear the voice of calling party from the speaker.

Restart Talking

- (1) While receiving a voice from the speaker, lift the handset.
The Speaker key lamp goes off.

Talking Handsfree

You can dial or answer a call without lifting the handset.

Set Handsfree

- (1) Press the **MIC** key or the **MIC** softkey.
The MIC key lamp lights red.

Cancel Handsfree

- (1) Press **MIC** key or the **MIC** softkey.
The MIC key lamp goes off.

Make a Call Handsfree

- (1) MIC key lamp is goes off, press the **Speaker** key.
The Speaker key lamp lights red.
- (2) Dial the desired number.
- (3) The called party answers.
Press MIC key or the MIC softkey.
The MIC key lamp lights red.
Talk toward the MIC.

Answer a Call Handsfree

- (1) The Call Indicator Lamp flashes.
- (2) Press the **Speaker** key.
The Speaker key lamp lights red.
Talk toward the MIC.



When you make a call handsfree, note the following items.

Avoid using in a place where there is a lot of echo or noise.

The Microphone is located at the front of the terminal. It should be no further away than 50 cm (19.69 inches).

When talking handsfree, be aware of the volume level so you do not disturb people close to you.

Talk alternately with the other party. The voice may be interrupted if both party talk at the same time.

Call Pickup – Group

This feature permits users to answer any calls directed to other extensions in their preset pickup group.



This feature is set using a Softkey or Feature key. The Feature key is set by system data setting at initial installation.

For details, contact the system administrator.

- (1) When the telephone in you pickup group rings, press the **Speaker** key.
The Speaker key lamp lights red.
- (2) Press ↓.
- (3) Press **P/U**.
- (4) Press **P/U**.
- (5) Start the conversation with the calling party.

Call Pickup – Direct

This feature permits a terminal user to pickup a call to any other terminal in the system.



The Feature key is set by system data setting at initial installation.

For details, contact the system administrator.

- (1) Press the **Speaker** key.
The Speaker key lamp lights red.
- (2) Press ******.
The Speaker key lamp lights red.
- (3) Dial the extension number of the telephone that is ringing.
- (4) Start a conversation with calling party.

Multiline Appearance

This feature allows you to accommodate the lines (another terminal number) other than My Line on the Programmable line/feature keys.

When accommodating another terminal number on the programmable line/feature key, you can answer the call routed to another by pressing the key that is assigned.



The Feature key is set by system data setting at initial installation.

For details, contact the system administrator.

Answer a Call

- (1) A call is terminated to the telephone whose terminal number is accommodated to the **Multiline Appearance** feature key.

The Call Indicator Lamp flashes.
The Multiline key lamp flashes red.

- (2) Press Multiline Appearance feature key.

The Call Indicator Lamp goes off.
The Speaker key lamp lights red.

- (3) Lift the handset to start a conversation.

The Speaker key lamp goes off.



When you press a Feature key with a call in progress, the call is disconnected.

DND (Do Not Disturb)

This feature restricts incoming calls to a terminal.



*This feature is set using a Softkey or Feature key. The Feature key is set by system data setting at initial installation.
For details, contact the system administrator.*

Set DND

- (1) Press ↓.
- (2) Press **Prog.**
- (3) Press **DND.**
- (4) Press **Set.**
- (5) Select the DND type.

Cancel DND

- (1) Press ↓.
- (2) Press **Prog.**
- (3) Press **DND.**
- (4) Press **Cncl.**

Save and Repeat a Number

This feature allows a specific dialed number saved to the telephone and then you can redial that number.



*This feature is set using a Softkey or Feature key. The Feature key is set by system data setting at initial installation.
For details, contact the system administrator.*



Up to three Save and Repeat feature keys can be assigned per telephone.

Set Save and Repeat

- (1) Dial the desired number and press **Saved Number Redial (30)** or dial the access code.

Dial using Save and Repeat

- (1) Press **Speaker** key.
You receive a dial tone.
The Speaker key lamp lights red.
- (2) Press **Saved Number Redial (30)** or dial the access code.
- (3) Lift the handset to start a conversation.
Speaker key lamp goes off.



Redialing the same number is possible until a new number is registered by this feature.

Trunk Queuing – Outgoing

This feature allows you to set a call and enter a first-in, first-out queue when upon there is a busy signal on a trunk. As soon as an outgoing trunk becomes available, telephone that in the queue are called back on a first-in, first-out basis.



*This feature is set using a Softkey or Feature key. The Feature key is set by system data setting at initial installation.
For details, contact the system administrator.*

Set Trunk Queuing – Outgoing



This feature is only available for the telephone that is set by system data setting at initial installation.

- (1) Press the **Speaker** key and dial the outgoing access code.
The Speaker key lamp lights red.
The Line key lamp lights red.
The lines are all busy status.
You receive a busy tone.
- (2) Press **Camp** or **Camp-On (35)**.
The Camp-On (35) lamp lights red.
The Outgoing feature key lamp lights red.
- (3) Press the **Speaker** key.
The Speaker key lamp goes off.
Wait until the outgoing line is available

When the Trunk is Available

- (1) You hear the external incoming call ring.
The Call Indicator Lamp flashes red.
Line key lamp flashes green.
- (2) Lift the handset or press the **Speaker** key.
The outgoing feature key lamp goes off.
The Call Indicator Lamp goes off.
The Line key lamp lights green.
- (3) Dial the desired number.

Cancel Trunk Queuing – Outgoing



This feature is only available for the telephone that is set by system data setting at initial installation.

- (1) Press **Camp-On (35)**.
CAMP CANCEL displays on the telephone LCD.
The Camp-On (35) lamp goes off.

Call Back

This feature allows a calling party to set an automatic Call Back when a busy or no answer condition is encountered. When the busy terminal becomes idle, the terminal that set the Call Back is called.



*This feature is set using a Softkey or Feature key. The Feature key is set by system data setting at initial installation.
For details, contact the system administrator.*

Set Call Back



This feature is only available for the telephone that is set by system data setting at initial installation.

- (1) The called party extension is busy or no answer.
- (2) Press the **Camp** or **Camp-On (35)**.
- (3) Replace the handset.

Wait for Call Back.

When the Busy Terminal Becomes Idle

- (1) The telephone, which set Call Back, is alerted by a ringing.

When busy terminal becomes idle or the telephone that did not answer initiates or answers a call or accesses a feature and then becomes idle, the telephone used to set Call Back is alerted by ringing.

The Call Indicator Lamp flashes.

- (2) Lift the handset.

The extension number that was busy/no answer is automatically dialed.

Cancel Call Back



This feature is only available for the telephone that is set by system data setting at initial installation. This feature cannot be canceled using a softkey.

- (1) When the telephone is set with the Call Back feature, the Call Back feature key lamp lights red.
- (2) Press **Camp-On (35)**.
CAMP CANCEL displays on the telephone LCD.
The Camp-On (35) lamp goes off.

Timed Queuing (Outside Line Only)

When a user originates an outgoing trunk call and the called party is busy or does not answer, the caller can set the Timed Queuing. When this feature is set, the trunk seizure is repeated and the number is dialed again after a predetermined time interval.



The feature key is set by system data setting at initial installation.

For details, contact the system administrator.

- (1) Press the **Speaker** key.
You receive a dial tone.
The Speaker key lamp lights red.
- (2) Dial the **Outside Line access code**.
- (3) Dial desired number.
You receive a busy tone or a ring no answer from distant end.
- (4) Press **Camp** or **Camp-On (35)**.
- (5) Leave the speaker on.
The desired number automatically redials.
- (6) Start the conversation with the called party.



A busy tone is sent to the calling party when the call is made to the extension that is in Timed Queue mode.

Make/Answer a Call with Call in Progress

This feature allows you to put to hold a call in progress by pressing the Call Hold feature key. This line can then be used for originating another call or answering another incoming call. After finishing another call and replacing the handset, the original held call rings back.



It is required that the dedicated feature key other than fixed feature key (Hold) be set by system data setting at initial installation.

For details, contact the system administrator.

- (1) While call in progress, the Line key lamp lights red.
- (2) Press **Hold**.
The Hold lamp does not light.
The called party receives a hold tone.
- (3) To make a call to another party or answer the incoming call, replace the handset after finishing a call.
- (4) The original call rings back.
The Call Indicator Lamp flashes.
The Line key lamp flashes green.
- (5) Lift the handset to restart a conversation.
The Line key lamp lights green.

Station Hunting

When a busy terminal that is assigned a Station Hunting pilot number is called, this feature permits the incoming call to be routed to another telephone within the hunt group.



The telephone that is assigned the Station Hunting feature and the pilot number are set by system data setting at initial installation.

For details, contact the system administrator.



You cannot set Call Back, Call Waiting or Executive Override to the pilot number of the hunt group.

- (1) Lift the handset.
- (2) Dial the desired number.
If the pilot number is busy, the call is routed to another telephone within the hunt group.
- (3) Start a conversation with called party.

Step Call

This feature allows the terminal user, after calling a busy terminal, to call an idle terminal by simply dialing an additional digit.



The feature key is set by system data setting at initial installation.

For details, contact the system administrator.

- (1) Lift the handset.
The Line key lamp lights green.
- (2) Dial the extension number.
You receive a busy tone.
- (3) Enter the specific digit.



You can randomly select the last digit of the extension number from 0~9.

Call Waiting

This feature allows a terminal to camp itself on to a busy terminal.



This feature is available only for the telephone that is set by system data setting at initial installation.

For details, contact the system administrator.

Activate Call Waiting

- (1) You receive a busy tone.
- (2) Press **Camp** or enter **#**.
- (3) Do not hang up, wait until the call is available.

Answer Call Waiting

- (1) With the call in progress, the Call Waiting feature is set.
- (2) When the call is completed, the call waiting number is automatically dialed.
- (3) Press **Speaker**.

Executive Override

This feature allows selected users to override a busy condition on a called telephone.



The feature is set by system data setting at initial installation.

For details, contact the system administrator.

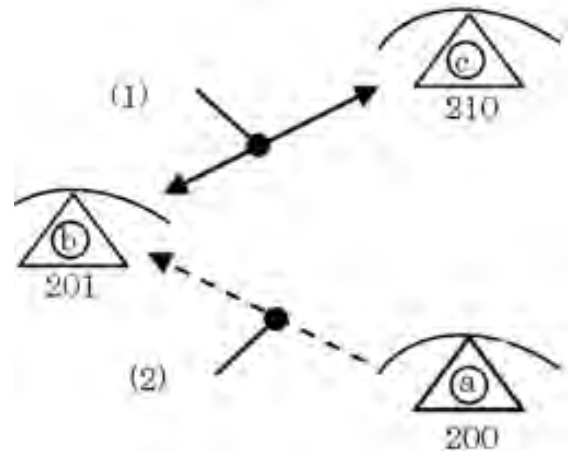

- (1) Call in Progress
- (2) Override

In this example (see diagram above), the party on telephone **B** is talking with the party on telephone **C**. The party on telephone **A** is going to override the connection.

- (1) The party on telephone **A** dials 201. (The called party is already on a call.)

- (2) Party **A** presses the **Barge-In (34)** or dials the access code.

Party A receives a warning tone.

Parties A, B and C are talking.

Call Forwarding – Busy Line

This feature permits a call to a busy extension to be routed to a designated terminal.

Set Call Forwarding – Busy Line

- (1) Press **Speaker**.
- (2) Dial the **access code**.
- (3) Enter **1**.
- (4) Enter the number to be transferred.
- (5) Press **Speaker**.
-- OR --
- (1) Press ↓.
- (2) Press **Prog**.
- (3) Press **Cfwd**.
- (4) Press **BUSY**.
- (5) Press **SET**.
- (6) Enter the number to be transferred.
- (7) Press **Speaker**.

Verify Call Forwarding – Busy Line

- (1) Press **Speaker**.
- (2) Dial the **access code**.
- (3) Enter **1**.
-- OR --
- (1) Press ↓.
- (2) Press **Prog**.
- (3) Press **Cfwd**.
- (4) Press **BUSY**.
- (5) Press **SET**.

Cancel Call Forwarding – Busy Line

- (1) Press **Speaker**.
- (2) Dial the **access code**.
- (3) Enter **0**.
- (4) Press **Speaker**.
-- OR --
- (1) Press ↓.
- (2) Press **Prog**.
- (3) Press **Cfwd**.
- (4) Press **BUSY**.
- (5) Press **CNCL**.

Call Forwarding – No Answer

When a call is placed to a telephone party who does not answer, this feature forwards the call to another telephone party.

Set Call Forwarding – No Answer



The softkey that is used as Call Forwarding - No Answer is the same one used for Call Forwarding - Busy Line (FDN softkey).

- (1) Press **Speaker**.
- (2) Dial the **access code**.
- (3) Enter **1**.
- (4) Enter the number to be transferred.
- (5) Press **Speaker**.
- OR --
- (1) Press ↓.
- (2) Press **Prog**.
- (3) Press **Cfwd**.
- (4) Press ↓.
- (5) Press **N/A**.
- (6) Press **SET**.
- (7) Enter the number to be transferred.
- (8) Press **Speaker**.

Verify Call Forwarding – No Answer

- (1) Press **Speaker**.
- (2) Dial the **access code**.
- (3) Enter **1**.
- OR --
- (1) Press ↓.
- (2) Press **Prog**.
- (3) Press **Cfwd**.
- (4) Press ↓.
- (5) Press **N/A**.
- (6) Press **SET**.

Cancel Call Forwarding – No Answer

- (1) Press **Speaker**.
- (2) Dial the **access code**.
- (3) Enter **0**.
- (4) Press **Speaker**.
- OR --
- (1) Press ↓.
- (2) Press **Prog**.
- (3) Press **Cfwd**.
- (4) Press ↓.
- (5) Press **N/A**.
- (6) Press **CNCL**.
- (7) Press **Speaker**.

Call Forwarding – All Calls

This feature allows all calls directed to a particular extension to be rerouted to an alternate destination, regardless of the busy or idle status of the extension.

Set Call Forwarding – All Calls

- (1) Press **Speaker**.
- (2) Dial the **access code**.
- (3) Enter **1**.
- (4) Enter the number to be transferred.
- (5) Press **Speaker**.
-- OR --
- (1) Press ↓.
- (2) Press **Prog**.
- (3) Press **Cfwd**.
- (4) Press **All**.
- (5) Press **SET**.
- (6) Enter the number to be transferred.
- (7) Press **Speaker**.

Verify Call Forwarding – All Calls

- (1) Press **Speaker**.
- (2) Dial the **access code**.
- (3) Enter **1**.
-- OR --
- (1) Press ↓.
- (2) Press **Prog**.
- (3) Press **Cfwd**.
- (4) Press **All**.
- (5) Press **SET**.

Cancel Call Forwarding – All Calls

- (1) Press **Speaker**.
- (2) Dial the **access code**.
- (3) Enter **0**.
-- OR --
- (1) Press ↓.
- (2) Press **Prog**.
- (3) Press **Cfwd**.
- (4) Press **All**.
- (5) Press **CNCL**.

Call Forwarding – Destination

This feature allows Call Forwarding - All Calls to be set from another station within the system.



*The feature is set by system data setting at initial installation.
For details, contact the system administrator.*

Set Call Forwarding – Destination

- (1) Press **Speaker**.
- (2) Dial the **access code**.
- (3) Enter **1**.
- (4) Enter the number to be transferred.
- (5) Press **Speaker**.
-- OR --
- (1) Press ↓.
- (2) Press **Prog**.
- (3) Press **Cfwd**.
- (4) Press ↓.
- (5) Press **Flw**.
- (6) Press **SET**.
- (7) Enter the number to be transferred.
- (8) Press **Speaker**.

Cancel Call Forwarding – Destination

- (1) Press **Speaker**.
- (2) Dial the **access code**.
- (3) Enter **0**.
-- OR --
- (1) Press ↓.
- (2) Press **Prog**.
- (3) Press **Cfwd**.
- (4) Press ↓.
- (5) Press **Flw**.
- (6) Press **CNCL**.

CID (Caller ID) Call Display

Without answering incoming calls or held calls that terminate to the telephone line keys, the calling party's information can be confirmed by the indications on the LCD.

Display Calling Party Information

- (1) Press **List**.
- (2) Press **CID**.

Answer a Voice Call Handsfree

This feature allows the you to answer a Voice Call without lifting the handset.

- (1) When you receive an incoming Voice Call, press the **MIC** key.

The **MIC** key lamp lights red.

- (2) Respond to call handsfree.

Internal Zone Paging With Meet-Me Page

This feature allows terminal users to page over the built-in speakers of the terminals within the assigned zone or all zones.



*The feature access code/feature key is set by system data setting at initial installation.
For details, contact the system administrator.*

Initiate Page (Terminal A)

Telephone party A pages telephone party B.

- (1) Press the **Speaker** key.

You receive a dial tone.

Speaker key lamp lights red.

- (2) Dial the Internal Paging **access code** for the desired zone or all zones or press the **Internal Paging** feature key for the desired zone or all zones.

- (3) Page telephone party **B**.

Answer Page (Terminal B)

- (1) Dial the **Meet-Me Answer** access code.
Both parties are immediately connected.

Boss/Secretary Calling

A secretary with a telephone can use an appearance of the boss' extension to screen calls for that extension, and announce and/or transfer calls to that extension. Additionally, the secretary can call the boss during a busy condition and can send a message waiting indication to the boss's telephone.



*The feature access code/feature key is set by system data setting at initial installation.
For details, contact the system administrator.*

Call Boss from Secretary

- (1) Press **Secretary Call (42)**.

The Secretary Call (42) lamp lights red.

- (2) When the boss's line rings, transfer the call to the secretary's line.
- (3) When the secretary's line answers, announce the call to the boss.

When the Boss Accepts the Call

- (1) The secretary presses **Transfer** or **Trf**.

Return Message Schedule

This feature allows a telephone user to register a return schedule when leaving the office and have the schedule display on the calling telephone LCD.



*The feature access code/feature key is set by system data setting at initial installation.
For details, contact the system administrator.*

Set Return Message Schedule

- (1) Press the **Speaker** key.
You receive a dial tone.
The Speaker key lamp lights red.
- (2) Dial the **Return Message Schedule** access code or press the **Return Message Schedule** feature key.
- (3) Dial the number corresponding to desired message.

Message Patterns:

No.	Message	Change “#” to...
1	IN MEETING UNTIL ###:##	Time (when meeting done)
2	MEETING ROOM - #####	Room name or extension
3	COME BACK ###:##	Time (when returning)
4	PLEASE CALL #####	11 digit telephone number
5	BUSY CALL AFTER ###:##	Time (when returning)
6	OUT FOR LUNCH BACK ###:##	Time (when returning)
7	BUSINESS TRIP BACK ###/##	Date (when returning)

No.	Message	Change “#” to...
8	BUSINESS TRIP #####	10 digits (where reached)
9	GONE FOR THE DAY	
10	ON VACATION UNTIL ###/##	Date (when returning)
11 ~20	MESSAGE 11~20	

Press **0** or **1** and the dial desired time.
Press **2** or **3** and dial the month and date
(Example: for June, 8, enter “0608”)

- (4) Press the **Speaker** key.
The Speaker key lamp goes off.
The Return Message Schedule is registered.

Cancel Return Message Schedule

- (1) Press the **Speaker** key.
You receive a dial tone.
The Speaker key lamp lights red.
- (2) Dial the **Return Message Schedule** cancel code.
- (3) Press the **Speaker** key.
Speaker key lamp goes off.

Whisper Page

This feature allows a secretary to interrupt the boss privately. By pressing a feature key or dialing an access code, the secretary's telephone can interrupt the conversation between the boss and another party. When the conversation is interrupted, the boss can hear the secretary but the other party is unaware of the voice override.



*The feature access code/feature key is set by system data setting at initial installation.
For details, contact the system administrator.*

- (1) Press **Secretary (42)**.
The Secretary Call (42) lamp lights red.
- (2) Dial the secretary number.
- (3) Press **Voice Over (48)** or dial the **access code**.
- (4) Listen to conversation and speak to the boss's telephone only.

Using a Headset

Make/Answer a Call with a Headset

You originate and respond to calls using an optional headset.

- (1) When call is received, press the **Headset/Handset** feature key. When the call is completed, press the **Headset/Handset** feature key again.

The Headset/Handset Answer key lamp goes off.
The Line key lamp goes off.



While on a call using handset, you can switch to the headset by pressing the Headset/Handset feature key.

You can answer a call by pressing Line key after pressing the Headset/Handset feature key.

You can also answer a call by pressing the Answer key after pressing the Headset/Handset feature key.

For details, please contact the system administrator.

Appendix A Menu List

Menu List

Menu Item	Description
Menu	Press  to display the Menu screen.
History	Select this option to view the Call History data. Also, you can add the history data to the directory.
Directory	Select this option to access the directory feature. There are the following three types of directory features: Personal Directory, Phonebook and Corporate Directory. This chapter explains the menu list for Personal Directory feature.
Service	Select this option to display the screen of XML application/Photo Frame application registered in the service URL.
Setting	Select this option to make the user setting of DT930/DT920.
Portal	Select this option to display XML application screen registered in the home URL.

Menu List for **History**

Menu Item	Description	Default Value
History	System history.	–

Menu List for **Directory**

Menu Item	Description	Default Value
Directory	Directory history.	–

Menu List for **Setting - Classic Mode (ITK-8LCX)**

Menu Item		Description	Default Value
Setting			
1	User Setting	Select this option to configure the user setting of DT930.	–
	1 Incoming Call	Select this option to set up for incoming calls.	–
	1 Offhook Ring	Select this option to specify whether to use the Off-hook ringing.	Enable
	2 Headset Ring	Select this option to specify whether to use the headset ringing.	Disable
	3 Ring Tone	Select a ringer tone for External Call and Internal Call. (Automatic / Tone Type 1~14 / Download 1~3)	Automatic (Tone Type 1)
	4 Illumination	Select this option to set the illumination pattern for External Call and Internal Call. (Automatic / Disable / Red / Green / Blue / Yellow / Purple Light Blue / White / Rotation)	Automatic (Red)
	2 Talk	Select this option to set up for telephone conversation.	–
	1 RTP Alarm	Select this option to specify whether to use the RTP alarm.	Automatic
	2 DTMF Tone	Select this option to specify whether to use the DTMF tone.	Automatic
	3 Key Touch Tone	Select this option to set the key touch tone generated when the digit keys are pressed while the telephone is off-hook.	Automatic (Tone)
	4 Hold Music	Select a Music on Hold to be heard by DT930 user.	Default
	5 Prefix	Select this option to register a Prefix number.	–
	3 Display	Select this option to set up for the LCD display.	–
	1 Calendar Format	Set calendar display format and time display format.	Automatic (12-hour format)
	2 Local Volume	Specify whether to display the following volume levels: handset receiver volume, speaker volume, ringer tone volume and LCD contrast.	Automatic (Enable)
	3 Screen Saver	Select this option to set up Screen Saver related data.	–
	1 Screen Saver Mode	Select this option to specify whether to use a Screen Saver.	Enable
	2 Wait Time	Select this option to specify the Wait Time to launch a Screen Saver.	30 min

Menu Item		Description	Default Value
	4 Back Light	Select this option to set the brightness of the backlight. 1. Level 1 (Bright) ~ 4. Level 4 (Dark)	Level 2
	5 Font Size	Select this option to change the font size displayed on an LCD.	Standard
	1 Large		
	2 Standard		
	6 Language	Select this option to select a language to be displayed on an LCD.	Automatic
	7 Advanced	Select this option to set up for the following additional data.	–
	1 Wallpaper <i>Note: Wallpaper is not supported at this time.</i>	Select this option to specify the Home screen background (default/download)	Default
	2 Font Color	Select this option to specify the font color for the Time Display/Feature Information Display area. *You can check the color by selecting each color number. (Color 1 ~ Color 16)	Color 16
	3 Turn Off Display	Select this option to specify the data when turning off the display automatically.	–
	1 Turn Off Display Mode	Select this option to set up for Turn Off Display Mode. (Disable/Enable/App Priority)	App Priority
	2 Wait Time	Select this option to specify the time until turning off the display. (1-999 min.)	180 min
	4 Backlight Fade Control	Select this option to specify whether Backlight Fade Control is in service, when turning on/off the backlight of the LCD. (Disable/Enable)	Enable
	5 Home Frame	Select this option to set home frame.	Enable
	4 Change Password	Select this option to change the password to lock/unlock the telephone.	0000
	5 Security	Not used.	–

Menu Item		Description	Default Value	
6 Usability		Select this option to set up for the operation of the Home key while Pop-up window is displayed.	–	
	1. Help Key Mode	Select this option to set up for Help Key Mode (1 SubMenu/2 Popup Window).	SubMenu	
	0 Setting Reset	Select this option to reset the telephone settings.	–	
2 Download		Set the data required when downloading a file.	–	
1 Download Files		Select this option to download files for Music on Hold, ringer tone, Directory and Wallpaper.	–	
1	1 Hold Music	Select this option to download a file for Music on Hold.	MOH.wav	
	2 Ring Tone	Select this option to download files for ringer tones (Download 1 to 3).	–	
	1	1 Music Ring 1	Select this option to download a file for ringer tone (Download 1).	Melody1.wav
		2 Music Ring 2	Select this option to download a file for ringer tone (Download 2).	Melody2.wav
		3 Music Ring 3	Select this option to download a file for ringer tone (Download 3).	Melody3.wav
	3 Directory	Select this option to download the directory files.	Directory.csv	
	4 Wallpaper	Select this option to download a file for Wallpaper.	WallPaper.bmp	
<i>Note: Wallpaper is not supported at this time.</i>				
2 Download Address		Select this option to enter an IP address of the FTP/TFTP/HTTPS server.	0.0.0.0	
3 Protocol		Select this option to specify a protocol of the server (either FTP or TFTP or HTTPS).	FTP	
4 Account Settings		Select this option to set necessary data when using FTP or HTTPS service.	–	
1	1 User ID	Select this option to enter a user ID for downloading via FTP or HTTPS server.	–	
	2 Password	Select this option to enter a password for downloading via FTP or HTTPS server.	–	
	3 Folder	Select this option to specify the directory where the downloaded file is stored.	–	

Menu Item		Description	Default Value
	3 Data Backup/Restore	Select this option to set the data required for a file backup/restore.	–
	1 Data Backup	Select this option to specify the file name to be backed up.	PersonalData.tgz
	2 Data Restore	Select this option to specify the file name to be restored.	PersonalData.tgz
	3 Server Address	Select this option to enter an IP address of the FTP/TFTP/HTTPS server.	0.0.0.0
	4 Protocol	Select this option to select a protocol of the server (either FTP, TFTP or HTTPS).	FTP
	5 Account Settings	Select this option to set necessary data when using FTP or HTTPS server.	–
	1 User ID	Select this option to enter a user ID for the data backup via FTP or HTTPS server.	–
	2 Password	Select this option to enter a password for data backup via FTP or HTTPS server.	–
	3 Folder	Select this option to specify the destination directory of FTP or HTTPS server.	–

Menu List for **Setting - Portal Mode (ITK-8LCX)**

Menu Item		Description	Default Value
Setting			
1	User Setting	Select this option to configure the user setting of DT930.	–
	1 Incoming Call	Select this option to set up for incoming calls.	–
	1 Offhook Ring	Select this option to specify whether to use the Off-hook ringing.	Enable
	2 Headset Ring	Select this option to specify whether to use the headset ringing.	Disable
	3 Ring Tone	Select a ringer tone for External Call and Internal Call. (Automatic / Tone Type 1~14 / Download 1~3)	Automatic (Tone Type 1)
	4 Illumination	Select this option to set the illumination pattern for External Call and Internal Call. (Automatic / Disable / Red / Green / Blue / Yellow / Purple Light Blue / White / Rotation)	Automatic (Red)
	2 Talk	Select this option to set up for telephone conversation.	–
	1 RTP Alarm	Select this option to specify whether to use the RTP alarm.	Automatic
	2 DTMF Tone	Select this option to specify whether to use the DTMF tone.	Automatic
	3 Key Touch Tone	Select this option to set the key touch tone generated when the digit keys are pressed while the telephone is off-hook.	Automatic (Tone)
	4 Hold Music	Select a Music on Hold to be heard by DT930 user.	Default
	5 Prefix	Select this option to register a Prefix number.	–
	3 Display	Select this option to set up for the LCD display.	–
	1 Calendar Format	Set calendar display format and time display format.	Automatic (12-hour format)
	2 Local Volume	Specify whether to display the following volume levels: handset receiver volume, speaker volume, ringer tone volume and LCD contrast.	Automatic (Enable)
	3 Screen Saver	Select this option to set up Screen Saver related data.	–
	1 Screen Saver Mode	Select this option to specify whether to use a Screen Saver.	Enable
	2 Wait Time	Select this option to specify the Wait Time to launch a Screen Saver.	30 min

Menu Item		Description	Default Value
	4 Back Light	Select this option to set the brightness of the backlight. 1. Level 1 (Bright) ~ 4. Level 4 (Dark)	Level 2
	5 Language	Select this option to select a language to be displayed on an LCD.	Automatic
	6 Advanced	Select this option to set up for the following additional data.	–
	1 Turn Off Display	Select this option to specify the data when turning off the display automatically.	–
	1 Turn Off Display Mode	Select this option to set up for Turn Off Display Mode. (Disable/Enable/App Priority)	App Priority
	2 Wait Time	Select this option to specify the time until turning off the display. (1-999 min.)	180 min
	2 Backlight Fade Control	Select this option to specify whether Backlight Fade Control is in service, when turning on/off the backlight of the LCD. (Disable/Enable)	Enable
	7 Portal Mode Setting	Select this option to set up for the following about Portal mode.	–
	1 Delete Shortcut	Select this option to delete shortcut.	–
	2 Change Theme	Select this option to set up for Display theme	White Theme
	1 White Theme	Select this option to set theme to White	–
	2 Black Theme	Select this option to set theme to Black	–
	3 Home Screen Setting	Select this option to set home screen.	Automatic
	4 Change Password	Select this option to change the password to lock/unlock the telephone.	0000
	5 Security	Not used.	–

Menu Item		Description	Default Value
	6 Usability	Select this option to set up for the operation of the Home key while Pop-up window is displayed.	-
	1 Help Key Mode	Select this option to set up for Help Key Mode (1 SubMenu/2 Popup Window).	SubMenu
	0 Setting Reset	Select this option to reset the telephone settings.	-
2 Download		Set the data required when downloading a file.	-
	1 Download Files	Select this option to download files for Music on Hold, ringer tone, Directory and Wallpaper.	-
	1 Hold Music	Select this option to download a file for Music on Hold.	MOH.wav
	2 Ring Tone	Select this option to download files for ringer tones (Download 1 to 3).	-
	1 Music Ring 1	Select this option to download a file for ringer tone (Download 1).	Melody1.wav
	2 Music Ring 2	Select this option to download a file for ringer tone (Download 2).	Melody2.wav
	3 Music Ring 3	Select this option to download a file for ringer tone (Download 3).	Melody3.wav
	3 Directory	Select this option to download the directory files.	Directory.csv
	2 Download Address	Select this option to enter an IP address of the FTP/TFTP/HTTPS server.	0.0.0.0
	3 Protocol	Select this option to specify a protocol of the server (either FTP or TFTP or HTTPS).	FTP
	4 Account Settings	Select this option to set necessary data when using FTP or HTTPS service.	-
1 User ID	Select this option to enter a user ID for downloading via FTP or HTTPS server.	-	
2 Password	Select this option to enter a password for downloading via FTP or HTTPS server.	-	
3 Folder	Select this option to specify the directory where the downloaded file is stored.	-	

Menu Item		Description	Default Value
	3 Data Backup/Restore	Select this option to set the data required for a file backup/restore.	–
	1 Data Backup	Select this option to specify the file name to be backed up.	PersonalData.tgz
	2 Data Restore	Select this option to specify the file name to be restored.	PersonalData.tgz
	3 Server Address	Select this option to enter an IP address of the FTP/TFTP/HTTPS server.	0.0.0.0
	4 Protocol	Select this option to select a protocol of the server (either FTP, TFTP or HTTPS).	FTP
	5 Account Settings	Select this option to set necessary data when using FTP or HTTPS server.	–
	1 User ID	Select this option to enter a user ID for the data backup via FTP or HTTPS server.	–
	2 Password	Select this option to enter a password for data backup via FTP or HTTPS server.	–
	3 Folder	Select this option to specify the destination directory of FTP or HTTPS server.	–

Menu List for **Setting - Portal Mode (ITK-8TCGX)**

Menu Item		Description	Default Value
Setting			
1	User Setting	Select this option to configure the user setting of DT930.	–
	1 Incoming Call	Select this option to set up for incoming calls.	–
	1 Offhook Ring	Select this option to specify whether to use the Off-hook ringing.	Enable
	2 Headset Ring	Select this option to specify whether to use the headset ringing.	Disable
	3 Ring Tone	Select a ringer tone for External Call and Internal Call. (Automatic / Tone Type 1~14 / Download 1~3)	Automatic (Tone Type 1)
	4 Illumination	Select this option to set the illumination pattern for External Call and Internal Call. (Automatic / Disable / Red / Green / Blue / Yellow / Purple Light Blue / White / Rotation)	Automatic (Red)
	2 Talk	Select this option to set up for telephone conversation.	–
	1 RTP Alarm	Select this option to specify whether to use the RTP alarm.	Automatic
	2 DTMF Tone	Select this option to specify whether to use the DTMF tone.	Automatic
	3 Key Touch Tone	Select this option to set the key touch tone generated when the digit keys are pressed while the telephone is off-hook.	Automatic (Tone)
	4 Hold Music	Select a Music on Hold to be heard by DT930 user.	Default
	5 Prefix	Select this option to register a Prefix number.	–
	3 Display	Select this option to set up for the LCD display.	–
	1 Calendar Format	Set calendar display format and time display format.	Automatic (12-hour format)
	2 Local Volume	Specify whether to display the following volume levels: handset receiver volume, speaker volume, ringer tone volume and LCD contrast.	Automatic (Enable)
	3 Screen Saver	Select this option to set up Screen Saver related data.	–
	1 Screen Saver Mode	Select this option to specify whether to use a Screen Saver.	Enable
	2 Wait Time	Select this option to specify the Wait Time to launch a Screen Saver.	30 min

Menu Item		Description	Default Value
	4 Back Light	Select this option to set the brightness of the backlight. 1. Level 1 (Bright) ~ 4. Level 4 (Dark)	Level 2
	5 Language	Select this option to select a language to be displayed on an LCD.	Automatic
	6 Advanced	Select this option to set up for the following additional data.	–
	1 Turn Off Display	Select this option to specify the data when turning off the display automatically.	–
	1 Turn Off Display Mode	Select this option to set up for Turn Off Display Mode. (Disable/Enable/App Priority)	App Priority
	2 Wait Time	Select this option to specify the time until turning off the display. (1-999 min.)	180 min
	2 Backlight Fade Control	Select this option to specify whether Backlight Fade Control is in service, when turning on/off the backlight of the LCD. (Disable/Enable)	Enable
	7 Portal Mode Setting	Select this option to set up for the following about Portal mode.	–
	1 Delete Shortcut	Select this option to delete shortcut.	–
	2 Change Theme	Select this option to set up for Display theme	White Theme
	1 White Theme	Select this option to set theme to White	–
	2 Black Theme	Select this option to set theme to Black	–
	3 Animation	Select this option to set up for animation enable/disable	Disable
	4 Home Screen Setting	Select this option to set Home screen.	Automatic
	5 Shortcut Photo & Name	Select this option to set photo and name indication of shortcut in Favorite screen.	Photo & Name
	4 Change Password	Select this option to change the password to lock/unlock the telephone.	0000
	5 Security	Not used.	–
	6 Option Device	Select this option to setup the usage of the peripheral equipment.	–
	1 Bluetooth	Set Bluetooth	–
	1 Bluetooth Mode	Select this option to specify whether Bluetooth is available.	Disable
	2 Pairing	Select this option to pair with the Bluetooth device.	–
	3 Additional Setting	Select this option to set inquiry time.	30 sec

Menu Item			Description	Default Value
		4 Bluetooth Information	Select this option to show Bluetooth information.	–
	7 Usability		Select this option to set up for the operation of the Home key while Pop-up window is displayed.	–
	1	Help Key Mode	Select this option to set up for Help Key Mode (1 SubMenu/2 Popup Window).	SubMenu
	0 Setting Reset		Select this option to reset the telephone settings.	–
2 Download			Set the data required when downloading a file.	–
	1 Download Files		Select this option to download files for Music on Hold, ringer tone, Directory and Wallpaper.	–
	1	Hold Music	Select this option to download a file for Music on Hold.	MOH.wav
	2 Ring Tone		Select this option to download files for ringer tones (Download 1 to 3).	–
	1	Music Ring 1	Select this option to download a file for ringer tone (Download 1).	Melody1.wav
	2	Music Ring 2	Select this option to download a file for ringer tone (Download 2).	Melody2.wav
	3	Music Ring 3	Select this option to download a file for ringer tone (Download 3).	Melody3.wav
	3 Directory		Select this option to download the directory files.	Directory.csv
2 Download Address			Select this option to enter an IP address of the FTP/TFTP/HTTPS server.	0.0.0.0
3 Protocol			Select this option to specify a protocol of the server (either FTP or TFTP or HTTPS).	FTP
4 Account Settings			Select this option to set necessary data when using FTP or HTTPS service.	–
	1 User ID		Select this option to enter a user ID for downloading via FTP or HTTPS server.	–
	2 Password		Select this option to enter a password for downloading via FTP or HTTPS server.	–
	3 Folder		Select this option to specify the directory where the downloaded file is stored.	–

Menu Item		Description	Default Value
	3 Data Backup/Restore	Select this option to set the data required for a file backup/restore.	–
	1 Data Backup	Select this option to specify the file name to be backed up.	PersonalData.tgz
	2 Data Restore	Select this option to specify the file name to be restored.	PersonalData.tgz
	3 Server Address	Select this option to enter an IP address of the FTP/TFTP/HTTPS server.	0.0.0.0
	4 Protocol	Select this option to select a protocol of the server (either FTP, TFTP or HTTPS).	FTP
	5 Account Settings	Select this option to set necessary data when using FTP or HTTPS server.	–
	1 User ID	Select this option to enter a user ID for the data backup via FTP or HTTPS server.	–
	2 Password	Select this option to enter a password for data backup via FTP or HTTPS server.	–
	3 Folder	Select this option to specify the destination directory of FTP or HTTPS server.	–



This page is for your notes.

Appendix B Input Characters

This chapter show the input characters for entering speed dialing, passwords, etc.

How to Input Characters

System/Station Speed Dialing Feature

Press the dial key to display the character. The character will be changed by repeatedly pressing the dial. After displaying the desired character, press  or .

Example: When entering “MARY SMITH”,

6# 2# 777# 999# 0# 7777# 6# 444# 8# 44#

M A R Y S M I T H

The following two input modes can be specified.

ABC: English input mode.

NUM: Number input mode.

Input mode switches over by repeatedly pressing the softkey (“ABC” → “NUM” → “ABC”).



Up to 4 characters can be entered for keyword searching.

Up to 16 characters can be registered for each name.

Up to 30 digits can be registered for each dial number.

Access Code: Up to 4 digits

Called Number: Up to 26 digits



The default setting is English input mode.



Menu Contents (Password Input)

The characters that can be entered, vary depending on the menu.

Example: Password input screen.

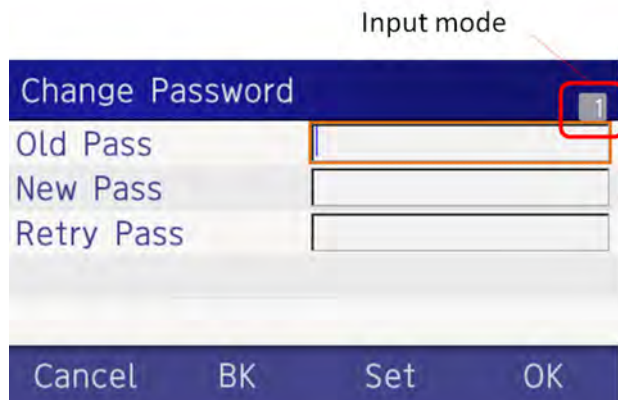

Input Mode

The characters used for the input mode on the Password Input screen are:

- 1** : Number
- A** : English Characters (Capital Letters)
- a** : English Characters (Lowercase Letters)



1 , **A** or **a** is shown on the first line of the LCD.

The following shows the input modes you can use for the listed menus.

Terminal Password

You can use the numeric input mode **1**. Other input modes are not allowed.

User ID, FTP/HTTPS Server Password, Folder Name, File Name and Address (URI) Input

You can use English characters (Capital letters **A** and Lowercase letters **a**) as well as numbers **1** .



*The initial setting is **A** (English Character - Capital Letter).*



*When ***** is pressed, the input mode is changed.*

*The input mode changes when ***** is repeatedly pressed.*

A **a** **1** **1**

IP Address

You can use numeric input mode **1** to enter the IP address. Other input modes are not available.

When ***** is pressed, move to the next input.

Input Character Tables

Common/Personal Directory Service Table

The following table lists character codes you can use for Common/Personal Directory Service.



Input 1~10 shows the number of times the key is pressed.

SP = Blank Space

INPUT	DIAL	1	2	3	4	5	6	7	8	9	10
ABC	①										
ABC	②	A	B	C	a	b	c				
ABC	③	D	E	F	d	e	f				
ABC	④	G	H	I	g	h	i				
ABC	⑤	J	K	L	j	k	l				
ABC	⑥	M	N	O	m	n	o				
ABC	⑦	P	Q	R	S	p	q	r	s		
ABC	⑧	T	U	V	t	u	v				
ABC	⑨	W	X	Y	Z	w	x	y	z		
ABC	⑩	SP	-	_	'	&	@	.	:	:	:
NUM	①	1									
NUM	②	2									
NUM	③	3									
NUM	④	4									
NUM	⑤	5									
NUM	⑥	6									
NUM	⑦	7									
NUM	⑧	8									
NUM	⑨	9									
NUM	⑩	0									

Menu Contents Tables

The following table lists character codes you can use for various menus.

Password Input



Input 1~10 shows the number of times the key is pressed.

SP = Blank Space

*When entering password characters, * is displayed on the screen.*

INPUT	DIAL	1	2	3	4	5	6	7	8	9	10
	①	1									
	②	2									
	③	3									
	④	4									
	⑤	5									
	⑥	6									
	⑦	7									
	⑧	8									
	⑨	9									
	⑩	0									
	Ⓢ	*									
	Ⓜ	#									

USER ID, Password (FTP/HTTPS Server), Folder Name, File Name, Address (URI) Input



Input 1~29 shows the number of times the key is pressed.

SP = Blank Space

When entering password characters, * is displayed on the screen.



When * is pressed, the input mode is changed.

The input mode changes when * is repeatedly pressed.

A a 1 1

INPUT	DIAL	1 16	2 17	3 18	4 19	5 20	6 21	7 22	8 23	9 24	10 25	11 26	12 27	13 28	14 29	15
A	①	.	,	\	1	?	!	@	:	;						
A	②	A	B	C	2											
A	③	D	E	F	3											
A	④	G	H	I	4											
A	⑤	J	K	L	5											
A	⑥	M	N	O	6											
A	⑦	P	Q	R	S	7										
A	⑧	T	U	V	8											
A	⑨	W	X	Y	Z	9										
A	⑩	SP	0													
A	⑪	* ?	# _	- +	/ -	: =	~ [!]	@ [\$]	% <	^ >	& .	(;) '	

INPUT	DIAL	1 16	2 17	3 18	4 19	5 20	6 21	7 22	8 23	9 24	10 25	11 26	12 27	13 28	14 29	15
a	①	.	.	\	1	?	!	@	:	:						
a	②	a	b	c	2											
a	③	d	e	f	3											
a	④	g	h	i	4											
a	⑤	j	k	l	5											
a	⑥	m	n	o	6											
a	⑦	p	q	r	s	7										
a	⑧	t	u	v	8											
a	⑨	w	x	y	z	9										
a	⑩	SP	0													
a	⑪	* ?	# _	. +	/ -	: =	~ [!]	@ (\$)	% <	^ >	& ?	(_) 	.

INPUT	DIAL	1 16	2 17	3 18	4 19	5 20	6 21	7 22	8 23	9 24	10 25	11 26	12 27	13 28	14 29	15
1	①	1														
1	②	2														
1	③	3														
1	④	4														
1	⑤	5														
1	⑥	6														
1	⑦	7														
1	⑧	8														
1	⑨	9														
1	⑩	0														
1	Ⓢ	*	#	@	/	()		-	_	:	'	~	&	\	

IP Address Input



*Input 1~10 shows the number of times the key is pressed.
(1) = Separator for the IP Address.*

INPUT	DIAL	1	2	3	4	5	6	7	8	9	10
1	①	1									
1	②	2									
1	③	3									
1	④	4									
1	⑤	5									
1	⑥	6									
1	⑦	7									
1	⑧	8									
1	⑨	9									
1	⑩	0									
1	*	(1)									
1	#										

This page is for your notes.

Appendix C To Upload an Image

Image Upload Procedure

Using the SV9100 User Programming function, you can upload an image related to the Shortcut Icon from your PC.

PC Connection and Setting

PC Requirements

Indicate the conditions of the PC used for User Programming.

OS: Microsoft Windows 8.1 / 10 (32bit and 64bit)

Browser:

- Internet Explorer 7, 8, 9, 10, 11
- Google Chrome v57 or higher
- Microsoft Edge

Other: RJ-45 LAN I/F connector

Connection

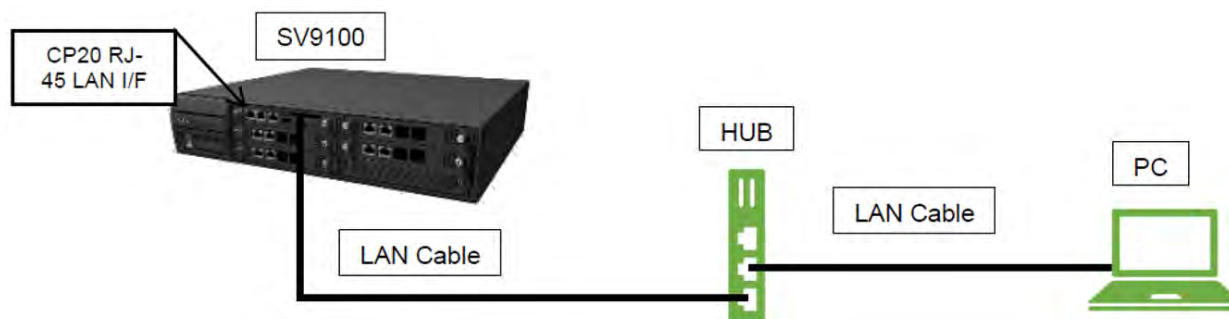

Maximum User Program PC Connection

You can log in to User Programming on a maximum of 4 PCs at the same time.

LAN Setting

For details, contact your dealer on how to set up your PC for connecting Web/User Programming to the SV9100 system.

User Programming Setup

- (1) Open a Web Browser on your PC.
- (2) Enter **https://192.168.0.10** on the URL address area and press the **Enter** key. The following Login menu is displayed.



- (3) Enter **User ID** and **Password**.
The following is the default User ID and Password.
User ID: USER1(NA), user1(other)
Password: 1111

Note: Enter User ID and Password using single-byte capital letters.

(4) Press the **Enter** key, the following is displayed.

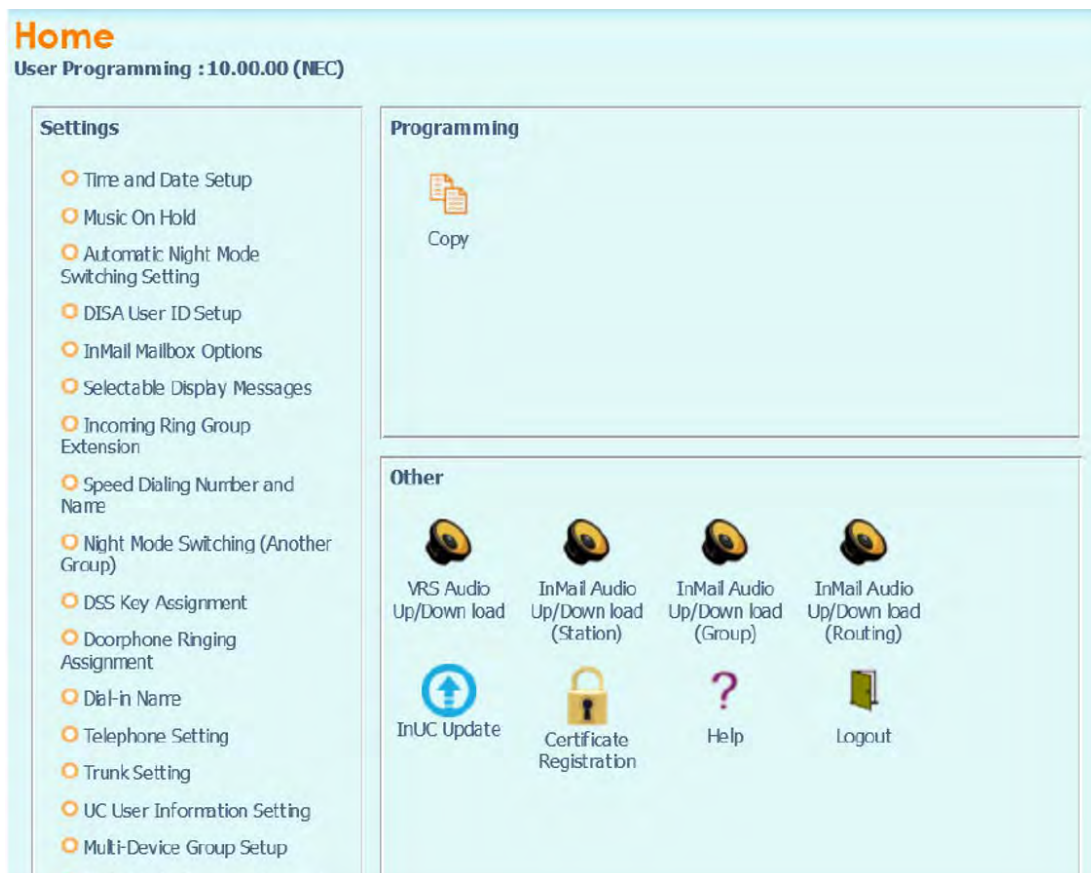

To Upload an Image

The following are specifications for uploading an image:

- Physical phone Extension users are target for photo image except Virtual Extension.
- A maximum of 896 images can be uploaded to the SV9100 system.
- After uploading an image to the SV9100 system, the SV9100 system will automatically download the image to each DT900 terminal.
- Save the images to be uploaded in advance.
- Image file(s) should be in .jpg format.
- The SV9100 resizes the image file to a certain size. There is no requirement for file size.

(1) From the Home screen, click on **Telephone Setting**.

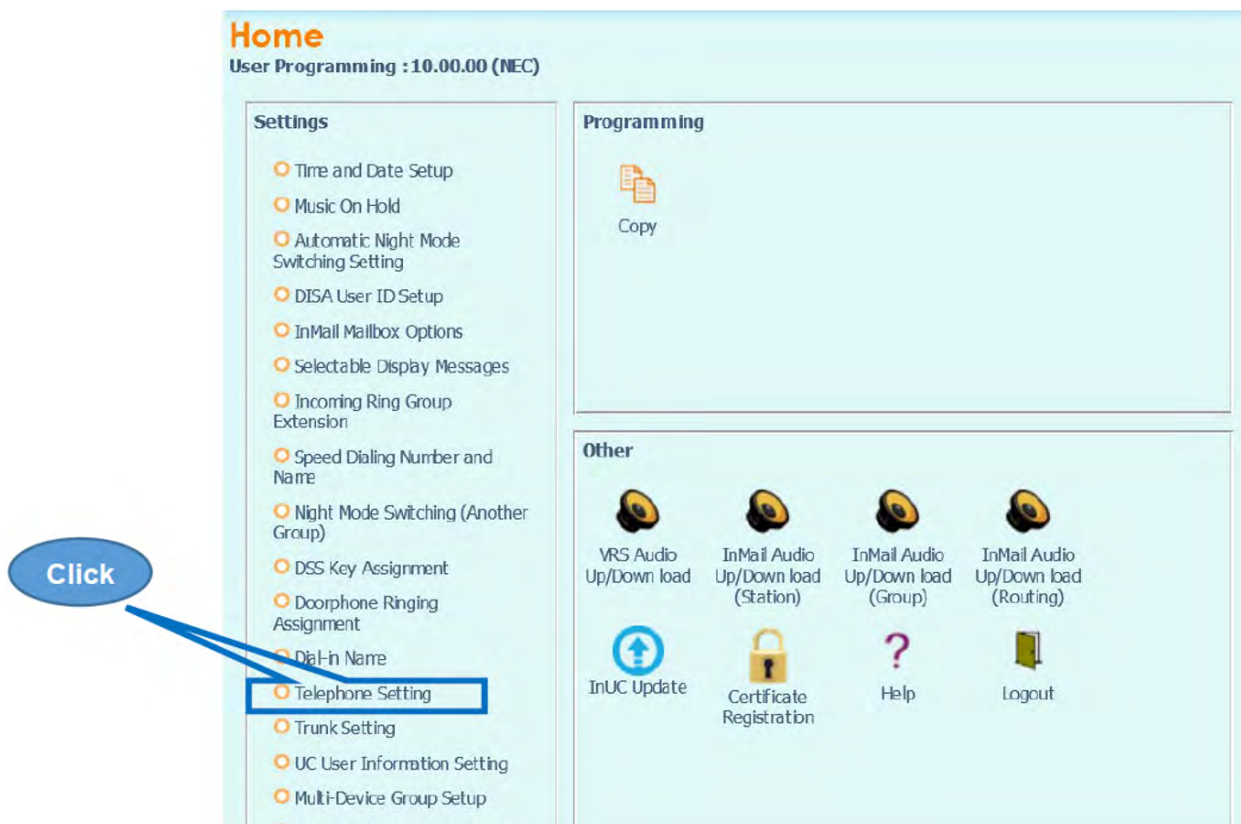

- (2) In the Telephone Setting screen, click on the **Details** icon for the extension you want to upload an image to on the SV9100. In the example shown, 101 is the target extension.

Telephone Setting

Apply Refresh Cancel Home

Port (1-960)

Extension Number

Click

Port	Extension	Terminal Type	Terminal Connection Status	IP Address	Availability of 1st Party CTI connection	Call Forward Type - Both Ring/All Call/No Answer	Call Forward Type - Busy	Call Forward Type - Follow-Me	Do Not Disturb	Details
001	101	MLT	Available	0.0.0.0	Not Available	Call Forward off	Call Forward off	Disable	No setting	
002	201	Not set	Not Available	0.0.0.0	Not Available	Call Forward off	Call Forward off	Disable	No setting	
003	202	Not set	Not Available	0.0.0.0	Not Available	Call Forward off	Call Forward off	Disable	No setting	
004	203	Not set	Not Available	0.0.0.0	Not Available	Call Forward off	Call Forward off	Disable	No setting	
005	204	MLT	Available	0.0.0.0	Not Available	Call Forward off	Call Forward off	Disable	No setting	
006	205	Not set	Not Available	0.0.0.0	Not Available	Call Forward off	Call Forward off	Disable	No setting	
007	206	Not set	Not Available	0.0.0.0	Not Available	Call Forward off	Call Forward off	Disable	No setting	
008	207	Not set	Not Available	0.0.0.0	Not Available	Call Forward off	Call Forward off	Disable	No setting	
009	208	Not set	Not Available	0.0.0.0	Not Available	Call Forward off	Call Forward off	Disable	No setting	
010	209	Not set	Not Available	0.0.0.0	Not Available	Call Forward off	Call Forward off	Disable	No setting	
011	210	Not set	Not Available	0.0.0.0	Not Available	Call Forward off	Call Forward off	Disable	No setting	

- (3) From the screen below, use the steps outlined to specify the image to be uploaded.
1. Specify the image file to be uploaded.
 2. Click on the upload icon.
 3. Preview the image.



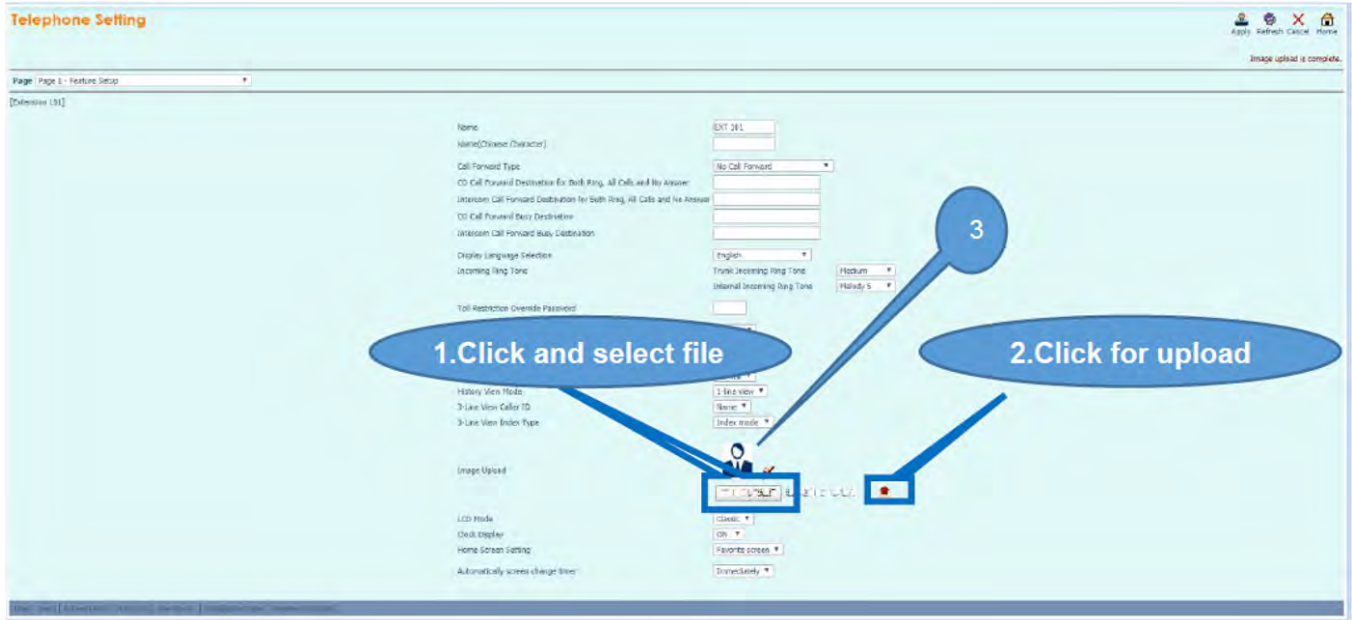



To delete the uploaded image, click the **Delete** icon.



Note: When upload is successful, "Image upload is complete." is displayed in the top right corner of the screen.

(4) To upload an image from another extension, click **Cancel** and repeat from step 2 above.

The screenshot shows the 'Telephone Setting' web interface. The page title is 'Telephone Setting'. Below the title, there is a breadcrumb trail: 'Page | Page 1 - Feature Setup'. The main content area is titled '(Extension 101)'. The interface is divided into two columns. The left column lists various settings categories, and the right column contains the corresponding input fields and dropdown menus. The 'Image Upload' section is highlighted with a blue box, and a blue arrow points to a 'Cancel' button. A blue oval with the word 'Click' is also present.

Setting Name	Value
Name	EXT 101
Name(Chinese Character)	
Call Forward Type	No Call Forward
CO Call Forward Destination for Both Ring, All Calls and No Answer	
Intercom Call Forward Destination for Both Ring, All Calls and No Answer	
CO Call Forward Busy Destination	
Intercom Call Forward Busy Destination	
Display Language Selection	English
Answering Ring Time	These Answering Ring Time: Medium
Intercom Answering Ring Time	Intercom Answering Ring Time: Priority 5
Tel Restriction Overview Password	
Right Mode Locking	Mode 2
Call Mail Password	1111
For See SpeedDial Control	Normal
History View Mode	3-Line view
3-Line View Caller ID	Name
3-Line View Index Type	Index mode
Image Upload	     
LCD Mode	Class
Clock Display	On
Home Screen Setting	Favorite screen
Automatically screen change time	Immediately

(5) When image upload is complete, click **Home** to exit the Telephone Setting screen.

Telephone Setting

App Refresh Cancel Home

Image upload is complete.

Page1 > Page 2 > Feature Setup

[Extension 201]

Name: EXT 101

Name(Chinese Character):

Call Forward Tone: No Call Forward

CO Call Forward Destination for Both Ring All Calls and No Answer:

Interim Call Forward Destination for Both Ring All Calls and No Answer:

CO Call Forward Busy Destination:

Transfer Call Forward Busy Destination:

Transfer Language Selection: English

Account Ring Tone: Frank Incoming Ring Tone Medium

Not Available/Over or Unavailable: Internal Incoming Ring Tone Heavy 5

Night Mode Selection: Mode 2



End User Password: 1111

Ten Key Backlit Control: Normal

Manual Speed Mode: 6 Star Long

Manual Speed Value: Normal

Manual Speed Value (2): No Use Mode

Image Upload:  

CO Mode: Class

Clock Display: On

Power Screen Setting: Available Screen

Automatically screen change timer: Immediately

(6) From the Home screen, click the **Logout** icon to log out.

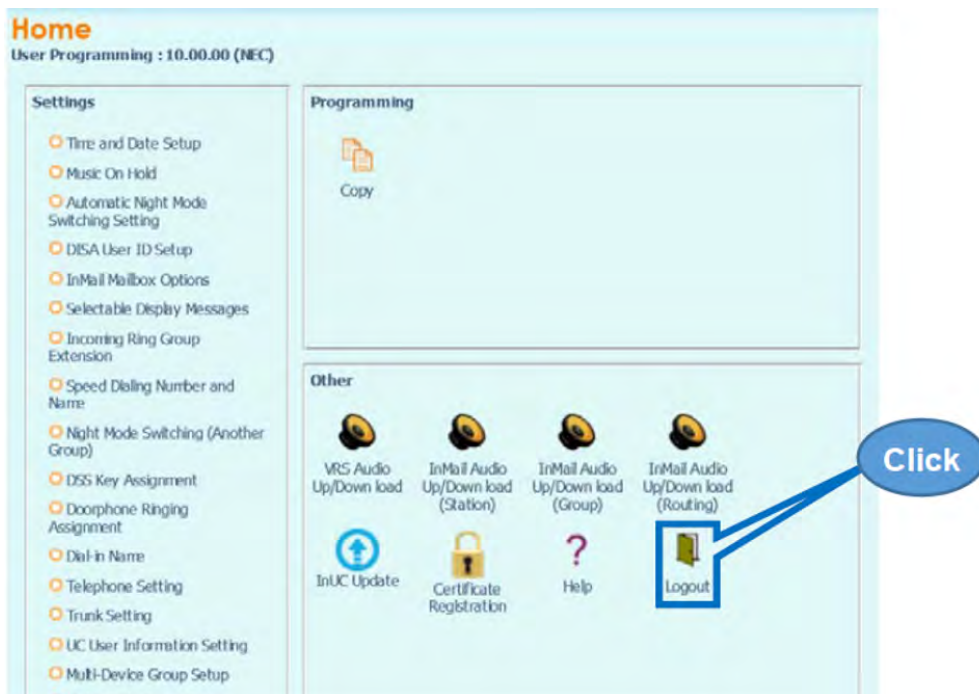

UNIVERGE[®] SV9100

DT930/DT920

(ITK-8TCGX/ITK-8LCX)

User Guide

NEC Enterprise Communication Technologies, Inc.

December 2023